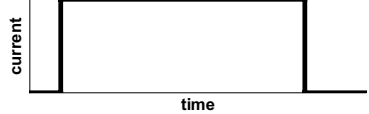
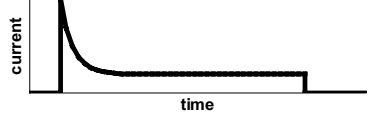
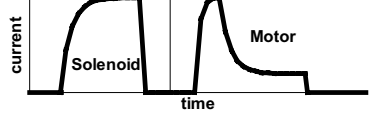

Automotive Applications

Typical Automotive Applications

Load	Application examples	Typical current curve
Resistive Loads	- Heatings (rear window heating, seat heating glow plug, air/water preheating)	
Capacitive Loads	- Lamps (front and rear beam, fog lights, flasher) - Filter capacitors in electronic modules (engine management module, ABS module)	
Inductive Loads	- Solenoids (vales, clutches, relay coils) - Motors and pumps (power window, central lock, cooling fan)	

Introduction

The range of applications can be classified into resistive loads, capacitive loads and inductive loads. The current curve of resistive loads is specified by the load voltage and load resistance. Capacitive loads have a high inrush current and a low steady current. Therefore lamps are counted to the capacitive loads, because the cold filament has a significantly lower resistance, than the hot filament. Inductive loads are characterized by an exponential current increase and a remarkable switch off arc, induced by the demagnetization of the magnetic circuit of the load. Power supply relays (clamp relays) can switch or feed a mixture of different loads.

The circuit design of resistive and capacitive loads is usually a simple switch on and switch off. Motor load circuits are often more complex. The most typical circuits are described hereafter.

Short-Circuit Brake

The short-circuit brake is used, wherever an electric motor must be braked (e.g. wiper). The short-circuit brake transforms the rotational energy of the motor into electrical energy. The short-circuit brake can be critical at higher load voltages. If the switch-off arc does not extinguish during the transition time of the movable contact, the arc creates a direct shortage of the power source. Particularly in 24VDC systems, the resulting extremely high arc current could cause almost instantly severe damage to the contacts and could destroy the entire relay.

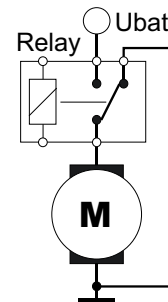

Fig. 1 Short-circuit brake

Motor-Reverse Circuit (H-Bridge)

The H-bridge is used to operate a motor in two directions (e.g. door lock, steering lock, power window, seat adjustment, etc.). The operation time is typically very short compared to the thermal time constant of the relay (e.g. door lock <1s, power window <10s). This means, H-bridge relays must be designed for high current-switching-capability, but not for high current-carrying-capability. Higher load voltages can be critical, due to possible short-circuit-arcs (see also short-circuit brake).

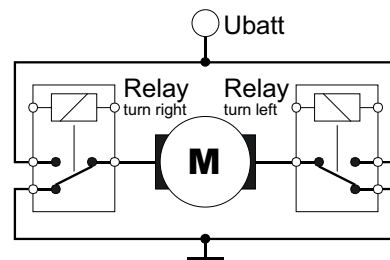

Fig. 2 H-bridge

Automotive Applications

Wiper Circuits

To stop the wiper in the correct position, a short-circuit brake is used. This can be done either by an internal slipping (usually used for rear wiper) or with the normally closed contact of the relay (usually used for front wiper). This requires a high switching capability of the N/C-contact, especially in combination with intermittent wipe function or rain sensor control. Dual speed wipers have two windings, which are commuted by a second relay. There are also wiper systems without mechanical gear, which are electrically reversed with a H-bridge circuit.

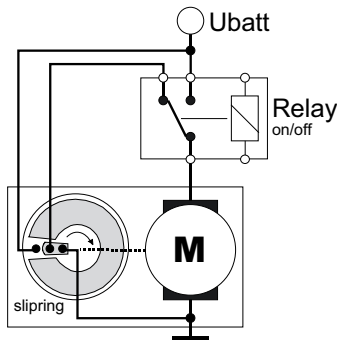

Fig. 3 Wiper with slipping

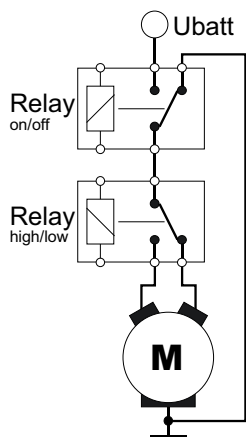

Fig. 4 Dual speed wiper-circuit

Cooling Fan Circuits

Depending on the size of the engine, either one or two fans are used to cool the engine. There are different possibilities to control the speed of the fans. Single fan systems are usually controlled by one or more serial resistors. The disadvantage is the electrical power loss of the resistors. Double fan systems are normally controlled by switching them either in series (low speed) or in parallel (high speed). If more speed steps are needed, additional serial resistors are used. A more sophisticated method is a PWM-controlled brushless motor. In commercial vehicles the cooling fan is mostly driven directly by the motor shaft.

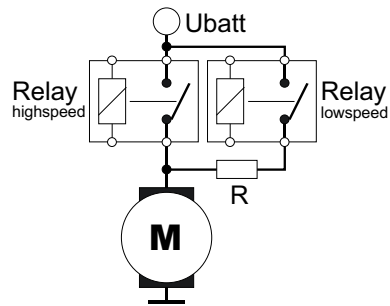

Fig. 5 Single fan circuit

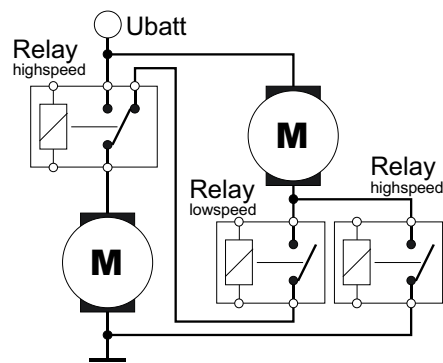

Fig. 6 Double fan circuit

Automotive Applications

Coil Suppression Circuits

The disconnection of the relay coil generates a transient voltage peak, which is only limited by the parasitic inductivity and capacity of the electrical system. In most of the cases it is necessary to suppress the transient voltage peak to typically 60VDC – 100VDC for the protection of the relay driver or the vehicle electrical system. Any voltage suppression of the relay coil influences the dynamics of the electromechanical system and can reduce the lifetime.

The best protection method for the driver is a diode in parallel to the relay coil. But this method has the worst influence on lifetime of the relay. Typical suppression methods are a resistor in parallel to the coil (preferably as internal component in plug-in relays) or a Zener diode in parallel to the relay driver (preferably for PCB relays).

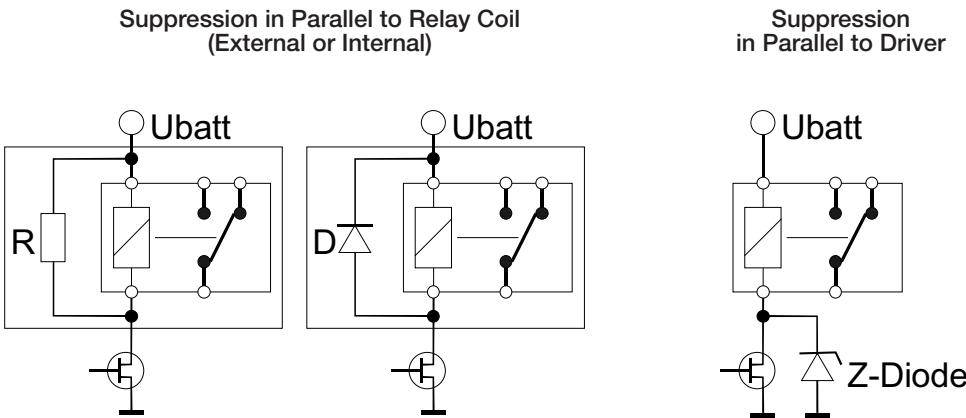

Fig. 7 Coil suppression circuits

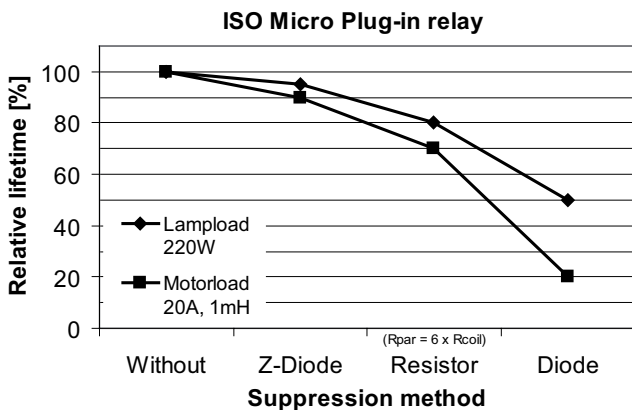

Fig. 8 Influence of coil suppression on the lifetime

Coil Suppression Can Reduce Relay Life

This application note deals with problems related to the methods used in deenergizing electromagnetic relay coils, particularly when a solid state switch is used, and how they affect relay life.

It is primarily concerned with the deenergization cycle of the relay, and discusses:

- 1) The armature and switching dynamics of the relay system upon coil deenergization.
- 2) How coil induced voltages occur.
- 3) Techniques for protecting the solid state switch.
- 4) The adverse effect of a simple coil suppression diode on relay switching dynamics and contact life.
- 5) The typical "sticking" between mating contacts and the reduced ability to break when using diode suppression.
- 6) How the addition of a Zener diode to the ordinary diode can provide both voltage suppression and reliable switching performance.

Relay deenergization or "drop-out" in typical clapper-type relays normally develops as follows: As the coil supply is interrupted, the magnetic flux decays to the point where the decreasing magnetic holding force (trying to keep the armature seated) drops below the spring forces (trying to unseat it), and armature opening commences. As armature opening continues, spring forces reduces according to the armature position; the countering magnetic force, however, reduces both with armature position and with decay of coil current (both of which reduce coil magnetic flux). As the electrical current in a relay coil is interrupted, an induced voltage transient of the order of hundreds or even thousands of volts may be generated across that coil as its magnetic flux, which is linked by the coil turns, collapses. This induced voltage, plus the coil supply voltage, as shown in Fig. 1, appears across the coil interrupting switch in a simple series switching circuit.

Figure 1- Operate & Release Dynamics Coil V & I, Typical DC Relay Without Diode

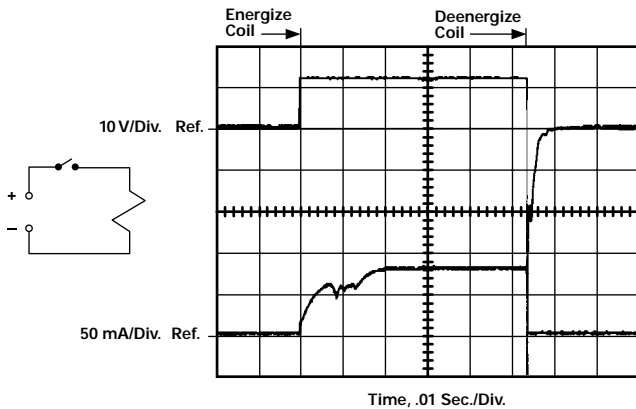

In today's logic control systems, a solid state switch is often used to operate a DC coil relay, and this switch is protected from coil deenergization induced voltages by various suppression techniques. These techniques are frequently effected by coil shunting means, designed to mitigate the suddenness of coil current interruption and resultant high rate of coil magnetic flux collapse.

One very common practice is to simply shunt the coil with a general purpose diode, placing the diode to block the source voltage and conduct with the reverse polarity of the coil induced voltage. This provides a path for the current flowing in the deenergized coil to be externally shunted back into the coil, limiting the magnitude of coil induced voltage to the forward drop of the diode, which the coil current, and resulting magnetic flux, slowly decay (see Fig. 2).

Figure 2- Operate & Release Dynamics Coil V & I, Typical DC Relay With Diode

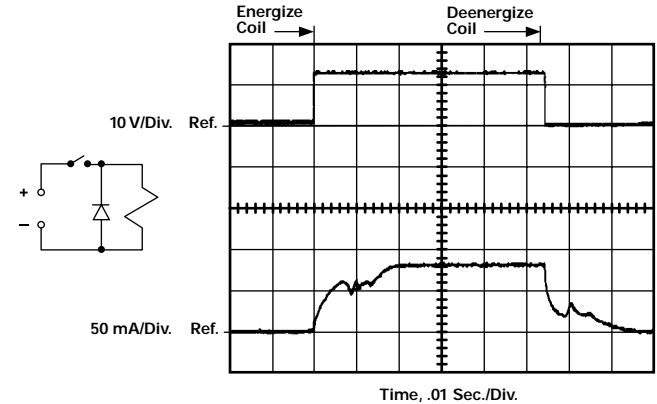

This diode shunt provides maximum protection to the solid state switch, but may have very adverse effects on the switching capability of the relay. It is important to realize that the net force available to cause the armature to open is the difference between the magnetic restraining forces and the spring opening forces, that each of these is varying in a manner to cause the net force to vary both with time and armature position. It is this net force which gives rise to the armature system velocity and energy of momentum as it attempts to effect armature and contact spring transfer.

A slowly decaying magnetic flux (the slowest is experienced with a simple diode shunt across the coil) means the least net force integral available to accelerate the armature open. In fact, rapid loss of the opening forces supplied by stiff NO contact springs, coupled with slowly decaying magnetic forces, can actually cause a period of net force reversal where the armature velocity is slowed, stopped, or even momentarily reversed until the flux further decays, finally permitting available spring "return" forces to cause transfer to continue.

It is equally important to realize that when the contacts of a typical power relay make, connecting very fast rising (e.g., resistive) medium or high current loads to the voltage source, a minute molten interface occurs between the mating contacts, giving rise to a microweld or stick condition that must be separated at the next opening transfer.

The "stick" force is normally well within the ability of the net opening force, aided by the momentum of the moving armature, to break the stick and effect contact transfer. However, the loss or even reversal of armature velocity (under conditions of simple diode shunting as described above), and accompanying loss of armature momentum needed to help break the contact stick, can result in failure to break the stick, and a contact "weld" is experienced.

The more rapidly the coil current decays, the less the magnetic hold back, and thus the greater the armature momentum and contact stick "break-ability."

Obviously, this is optimized when **no** suppression is used. However, near optimum decay rate can be obtained by using a Zener diode in series with a general purpose diode. When the coil source is interrupted, the coil current is shunted through this series arrangement, maintaining a voltage equal to the Zener voltage (plus forward diode drop) until the coil energy is dissipated. This is illustrated in Fig. 3.

**Figure 3- Operate & Release Dynamics Coil V & I,
Typical DC Relay With Diode & 24V Zener**

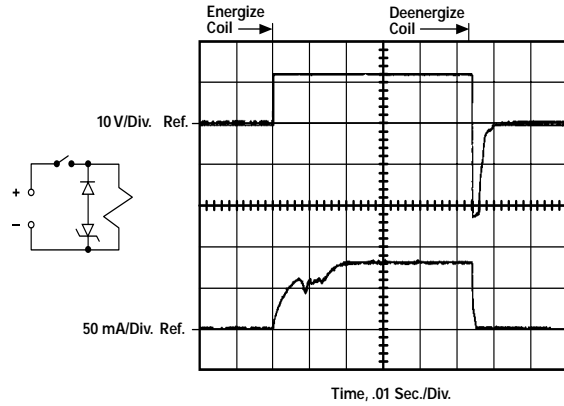

The Zener voltage value is chosen to limit the coil switch voltage to a level acceptable to the switch rating. This affords the best compromise both to coil switch protection and relay switching performance, and should be employed to assure maximum relay performance and reliability while providing protection to the control circuit from coil induced voltages.

It is normal industry practice to test relays and subsequently establish performance ratings without coil suppression. When application conditions require the suppression of coil induced voltages, it is recommended that the relay's performance be evaluated with the suppression that will be used.

Contact Arc Phenomenon

What precisely is an electric arc? How does it ignite and what causes it to extinguish? How does an arc affect the life of relay contacts?

These are some of the questions that we will discuss here. We hope to help you better understand how to obtain the longest life possible from relay contacts such as these.

But first, let's take a minute to define a few of the terms we'll be using.

First of all, "constriction" refers to the very first, tiny area of contact surface to make, and the very last point to break.

Melt Voltage is that amount of voltage that exists across the constriction which will cause a current sufficient to liquify the contact material at the constriction.

Arc Voltage is that amount of voltage that exists on contacts separated by a small gap that will cause an electric discharge across the gap.

And, lastly, Arc Current is that amount of current necessary to just sustain an arc caused by the arc-voltage electric discharge.

Now, keep these terms in mind as we take you into the world of relay contacts—a fairly harsh environment. Let's take a microscopic look at the effects of contact arcing.

As you know, the end result of contact arcing is shortened contact life. Depending on the severity and duration of the arc, each time an arc ignites, contact erosion occurs. This erosion causes a loss of contact material which will result in one of two conditions.

Condition #1 is where so much material is lost from the contacts that

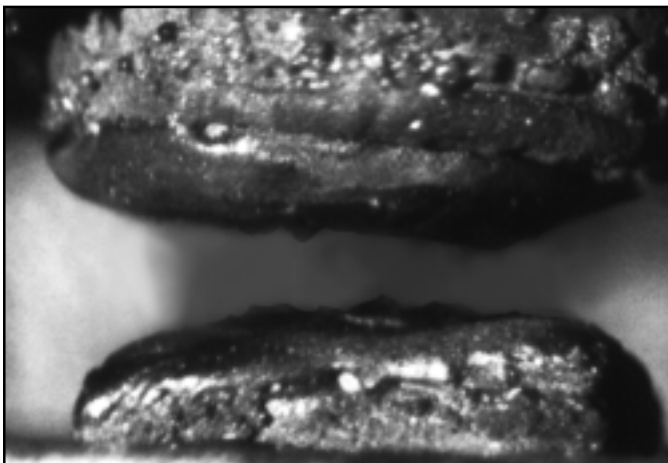

Condition #1

they fail to electrically close the load circuit. Condition #2 is where one contact loses so much material to the other contact that a spike-and-crater results.

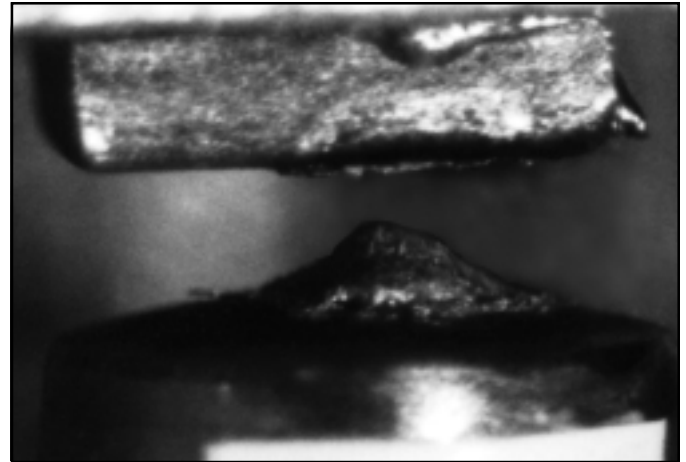

Condition #2

Another result of severe arcing which may occur now and then is contact welding. Usually, though, when this happens, it is evidence that the relay has been misapplied in a circuit where voltage and/or current are much greater than that particular relay can handle.

Regarding a spike-and-crater condition, when the condition gets severe enough, the high spot—that is, the spike—may mechanically hang up on the rim of the crater. Then when the relay is deenergized, the contacts fail to open, and the load is in an uncontrolled-on condition. Needless to say, this is an undesirable situation.

Typically, a spike-and-crater material transfer condition is associated with a direct current application. But we are beginning to notice that even in some alternating current applications, spike-and-crater material transfer is evident. This is because, in these applications, the relays are being operated in synchronization with the AC line voltage. This synchronization usually is the result of the synchronization to the AC line of the solid state logic or microcomputer circuitry that operates the relay. If synchronization just happens to occur at or near line voltage peak, then each time the relay contacts operate, they do so at or near either 170 volts or 340 volts, depending, of course, on whether line voltage is 120 or 240 volts.

If the application requires that the circuit clock be synchronized to the AC line, additional circuitry should be included to effect random operation of the relay. Or, synchronization might be set that the relay contacts open at or near current zero.

Just one further comment here regarding spike-and-crater material transfer. Don't automatically assume this type of transfer is the result of contact arcing. It may not be. Even in circuits in which no arc ignites, material transfer may occur. This is because the circuit voltage is greater than the melting voltage of the contact material and when the contacts

just come together or just separate, the material melts, travels from the hotter contact, the anode, to the cooler contact, the cathode, and remains there. In an AC application where operation is truly random, material transfers first one way one time and the other way another time. The net result is no appreciable gain of material by either contact. But in a DC application or in an application where the relay is synchronized to the AC line, material transfer is always in the same direction and a spike-and-crater condition may result.

When an arc ignites, material transfer is from cathode contact to anode contact. Therefore, in any given operation of the contact, before an arc ignites, material transfers from anode to cathode, and then when the arc ignites, material transfers from cathode to anode. The amount of transfer is usually greatest during the arc. Keep in mind, though, as just explained—and this is **important**—in a truly random AC application, the net material gain of either contact is negligible, while in a DC application or in an application synchronized to the AC line, there may be significant material gain by one contact.

Now, let's take a look at just what happens on contact closure. If you could examine the surface of a relay contact under a high power microscope, you'd see that the surface is quite irregular, consisting of deep low spots and a lot of high spots—with some spots higher than the others.

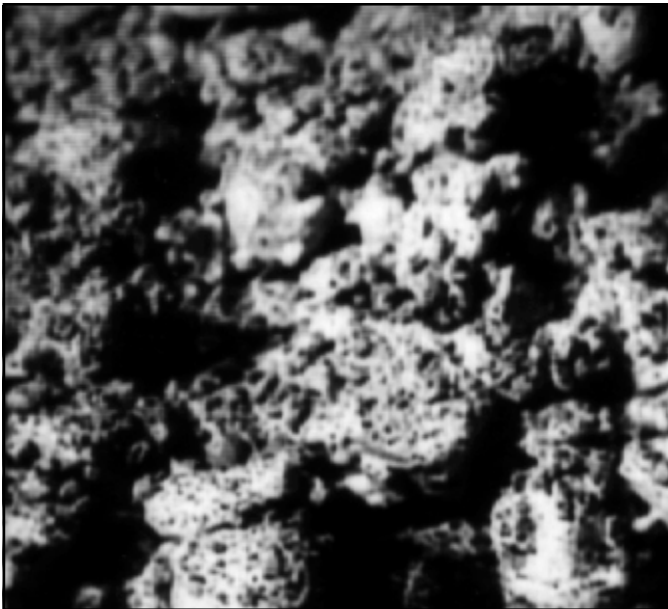

As the contacts just come together, the first high spot to make contact is subject to full load current. If load current is even a fraction of an ampere, the I^2R heat generated in this high spot instantly causes the high spot to melt and perhaps even boil. The air surrounding the high spot is superheated and begins to ionize by the loss of electrons. If I^2R energy is sufficient, the high spot may reach a temperature of 5,000 Kelvin or more and may explode, leaving superheated, ionized air and metallic ions in the gap between the contacts. Depending on contact material and the voltage stress on this air gap—that is, the contact voltage at the instant of the explosion—the ionized air gap may begin to conduct electron current from cathode to anode. This electric discharge between contacts is actually the beginning of an arc. If load current is in excess of the arc current rating of the contact material, the cathode spot in which I^2R heat is greatest may boil, thereby giving off atomic and even molecular emissions. These emissions are pulled through the arc column and

If an arc ignites, due to the Thompson effect there is a temperature gradient along the arc column, with the cathode being the hotter contact. That is, heat will flow from cathode to anode. The cathode spot in which I^2R heat is greatest may boil, thereby giving off atomic and even molecular emissions. These emissions are pulled through the arc column and

deposited on the slightly cooler anode contact. This, of course, is the principle of arc welding. All of this happens in perhaps ten nanoseconds or more as the contacts continue to move together.

The arc exists until the next high spot or high spots make. Again, the heat in these high spots may cause them to melt. When they do, they begin to spread out, increasing the area of contact make. As the contacts move together forcefully, this liquified metal may spatter, resulting in a loss of material. As the molten metal between the contacts cools, the contacts are frozen together in the normal manner. Unlike the catastrophic weld which may occur when a relay is misapplied, this weld is weak and easily broken by the action of the relay spring forces when the relay is deenergized. Now, think back! What actually had to happen before the arc could ignite? Was load current or voltage responsible for the arc? Well, certainly the arc must have a medium through which to travel, and the ionized gap between the contacts is that medium. And certainly it was load current heating of a contact high spot which caused the ions. But it was the voltage that existed across the contact gap that resulted in arc ignition. This voltage need not be load voltage. It may be circuit voltage. That is, upon contact make, there may be a certain amount of capacitance in the circuit that will charge through the contacts.

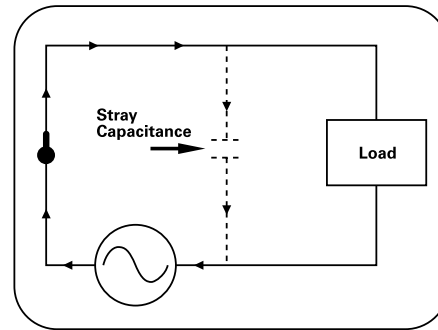

Also, if an arc-suppression capacitor is used across the contacts, this capacitance will discharge itself through the relay contacts.

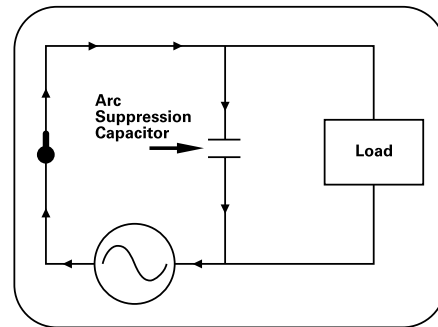

The discharge surge current may be hundreds of amperes for a few nanoseconds or more. To limit such discharge currents, an arc-suppression capacitor should have a certain amount of resistance in series with it. In circuits where there is no dedicated capacitance, however, there still may be sufficient stray capacitance to cause a momentary overcurrent upon contact make. This fact is often overlooked by many circuit designers.

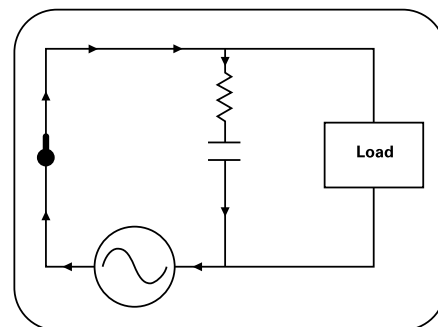

An arc ignites in similar manner upon contact break. As the contacts begin to separate, less and less contact area carries load current. Load current begins to funnel into this constricted area and I^2R heat begins to increase. The very last point of contact melts and, as the contacts continue to separate, a thin bridge of molten metal is stretched between the contacts. The air in the gap begins to ionize. The I^2R energy in the bridge generates so much energy that the bridge literally explodes, showering the gap with metallic ions. Again, if contact voltage is sufficient, an arc will ignite.

Different contact materials have different arc voltage ratings. For fine silver, the arc voltage is 12 volts. For cadmium, it is 10 volts; and for gold and palladium it is 15 volts. Let's assume the contacts are fine silver. Within nanoseconds after the molten bridge explodes, if the material is silver and if circuit voltage is 12 volts or more, voltage breakover occurs. If circuit voltage is less than 12 volts, breakover cannot occur and there will be no arc.

When an arc ignites between separating contacts, it will be sustained as long as there is sufficient energy to feed it. As long as the arc exists, material transfer will continue. In a direct current application, the arc can be extinguished only by stretching it to such a length that its own impedance causes it to extinguish, or by opening the circuit at some other point. In many applications, though, the contact gap is wide enough that the arc will extinguish before the contacts have fully opened. It is for this reason that relays of a given contact rating will be rated for, say, 120 volts AC, but will have a considerably lower DC voltage rating—usually 28 or 30 volts DC. That is, the gap is wide enough that, given the periodic swing through zero of alternating current, any AC arc should quickly extinguish. But the gap would not be wide enough for a 110 volt DC arc to extinguish.

In an AC application, depending on the temperature of the ionized air, even though arc current decreases to zero every half-cycle, the arc may reignite after current zero. This is because positive ions still exist between the contacts and it doesn't require much energy to reignite the arc.

It has long been recognized that, compared with fine silver, silver-cadmium-oxide contacts yield superior life in the presence of an arc. One theory says that since oxide coated materials produce negative ions when heated sufficiently, the negative ions produced by silver-cadmium oxide cause early recombination of the positive ions after current zero. This recombination causes the arc to extinguish earlier and may prevent reignition after current zero. This would seem to indicate that in an AC application where arcing is to be expected, silver-cadmium-oxide contacts protected with an appropriate arc suppression method should yield good contact life. We won't get into arc suppression techniques here because that's the subject of another application note titled "Relay Contact Life." All we will say about arc suppression here is that appropriate suppression can result in lengthened contact life. Additionally, by suppressing the arc, electromagnetic interference—EMI, for short—is held to a minimum. EMI is the result of atomic action in the arc column. In an arc plasma, the surface of the contacts is bombarded by atoms, positive and negative ions and electrons, some of which may be accelerated by passing through the electric field, and some of which may cause secondary emission of electrons which may radiate energy across a wide spectrum of frequencies. By quenching the arc quickly, this action is held to a minimum. The result often is a considerably lessened amount of electromagnetic and radio frequency interference.

In summation, to achieve the maximum life from arcing relay contacts, proper relay and contact application and the possible use of arc suppression are most important.

Beware of AC applications where the relay is synchronized to the AC line voltage. If synchronization is unavoidable, set the clock so that relay contact operation occurs at or near zero current.

And, when severe arcing conditions are expected, select a relay having silver-cadmium contact material.

Thank you for spending these past few minutes with us. We hope we've been able to help you better understand how to achieve the longest possible life from your relay contacts.

Definitions

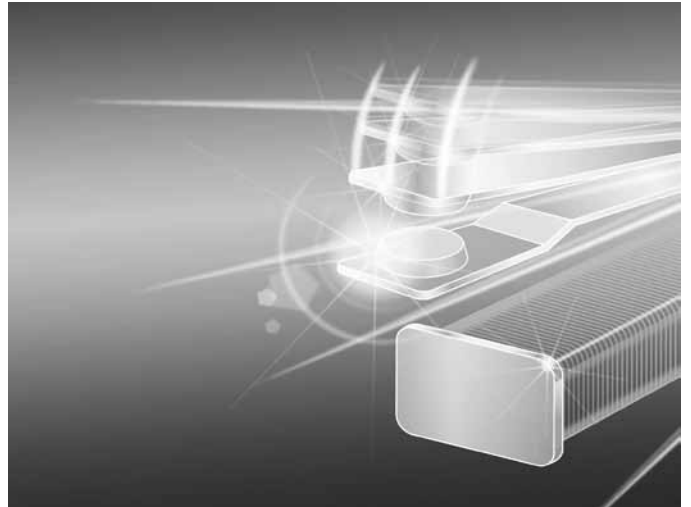

Definitions

Generalpage 2
Definitionspage 3

Handling, Processing, Testing and Use

Handling/Logisticspage 16
Processingpage 16
Testingpage 18
Usepage 19

Definitions (Continued)

General

While Tyco Electronics and its affiliates have made every reasonable effort to confirm the accuracy of the information contained in datasheets and catalogs, Tyco Electronics cannot assure that this information is error free. For this reason Tyco Electronics does not make any representation or offer any guarantee that such information is accurate, correct, reliable or current or does not infringe any intellectual property rights. Tyco Electronics reserves the right to make any adjustments to the information at any time.

Tyco Electronics expressly disclaims any implied warranty regarding the information contained in the datasheets and catalogs, including, but not limited to, the implied warranties of merchantability or fitness for a particular purpose. Tyco Electronics' only obligations and liability with respect to its products are governed solely by the Tyco Electronics' Standard Terms and Conditions of Sale for these products or the respective written agreement under which the products are supplied.

Technical data

Unless otherwise stated, the stated technical data are based on laboratory tests under standardized conditions and are within the conditions of normal use for these components. The vast number of influencing factors does not allow Tyco Electronics to test its products for all imaginable applications and processes. Furthermore, the large number of possible variations within a relay family makes it impossible to give a comprehensive description of the different characteristics for all variants in one datasheet. Typical data are derived from the standard versions.

The decision on the suitability of a specific component is solely responsibility of the user. To ensure the suitability of the product for a specific application the user has to test these products before the use under the most stringent conditions they will be exposed to in the actual application. Taking into consideration the aspects of operational availability and safety, the user has to rate the actual service life in an adequate relation to the expected life of the relay.

The use of the relay beyond its specified characteristics or beyond sufficiently tested life expectancy bears the risk of dangerous conditions; the user has to prevent such conditions by adequate measures, being entirely responsible in case of non-observance.

All product data are intended for users with knowledge and experience in the application of such specifications. The utilization is at the entire risk of the user.

The user has to verify the accordance with existing regulations and relevant standards for the application; in particular with reference to the insulation requirements as function of applied voltages and ambient conditions.

The standards (e.g. IEC 61810 'Electrical endurance') are based on the principal assumption of occurrences of malfunctions such as malfunction to make contact, malfunction to break or as insufficient dielectric strength. Such malfunctions have to be taken into consideration and must not generate risks. Depending on the specific load, its characteristics and power in the contact set, a relay malfunction situation may generate various risks such as malfunction of the equipment and its controls, electrical shock, the risk of excessive heat and fire and others. It is in the entire responsibility of the user to provide for additional precautions against such possible effects according to the relevant application standards.

Protection against risks under all operation conditions even in case of malfunction can only be ensured by the design of the equipment as well as by application instructions for the end user; it is the responsibility of the manufacturer of the equipment to take the appropriate measures. Incorrect connections by the user may lead to risks, faulty operation and abnormal heating or fire. It is also the responsibility of the manufacturer of the equipment to take appropriate measures to avoid potential danger of electrical shock by preventing access to live parts of the relay including parts as terminals and accessories.

TYCO ELECTRONICS WILL IN NO CASE BE LIABLE IN ANY CIRCUMSTANCES FOR ANY INCIDENTAL, INDIRECT, CONSEQUENTIAL DAMAGES OR LOSS OF PROFITS ARISING FROM OR IN CONNECTION WITH THE INFORMATION CONTAINED IN ITS DATASHEETS AND CATALOGS OR IN CONNECTION WITH ITS PRODUCTS, INCLUDING, BUT NOT LIMITED TO, THE SALE, RESALE, USE OR MISUSE OF ITS PRODUCTS. USERS SHOULD RELY ON THEIR OWN JUDGMENT TO EVALUATE THE SUITABILITY OF A PRODUCT FOR A CERTAIN PURPOSE AND TEST EACH PRODUCT FOR ITS INTENDED APPLICATION.

Specification

In order to improve performance and quality, we continuously develop our products. We reserve the right to change technical parameters and product specifications. The technical data listed are for description purposes of the components only and are not an agreement and do not guarantee specific characteristics and parameters; for detailed questions, please contact our application support. Drawings, photos data and descriptions are subject to change without prior notice.

Availability

The databooks and datasheets list a broad range of products and the descriptive part code structure (product code) does allow a large number of possible variations, but not all possible variations are defined as standard types in the current product portfolio (product code) and thus may not be included in the product range. Some products are normally maintained in stock for immediate delivery, or are available within 'normal leadtimes for industry'; however, there may be extended leadtimes for some non-stock items. Special versions to customer specifications may be supplied.

Additionally, minimum quantity requirements apply and these requirements may differ from indicated packaging units. Please consult with your Tyco Electronics sales organization or authorized distributor regarding availability and minimum order requirements.

Right to change the availability and delivery conditions reserved.

'Definitions', datasheets, product data, application notes and all specifications are subject to change.

Trademark

Tyco Electronics, TE-logo, AXICOM, OEG, P&B, POTTER & BRUMFIELD, PRODUCTS UNLIMITED, SCHRACK are trademarks.

Definitions (Continued)

AC-coil

Relays for direct energization with AC supply. If not otherwise stated, the data is given as V_{rms} for 50 Hz supply.

Adjacent contacts

Insulation parameters between two adjacent contact circuits (poles of a relay), which do not have a conductive connection. The level of insulation depends on the relays design, rated voltage and ambient conditions.

Ambient temperature (function, in operation)

The temperature in the vicinity of the relay (distance according to IEC 61810-1). The minimum ambient temperature is the minimum operating temperature, the maximum ambient temperature is the maximum operating temperature for the use of the relay or accessory when operated. This temperature range should not be exceeded; within the indicated temperature range the ambient temperature does influence the electrical endurance. Ambient temperature range according to IEC 61810-1 and indicated in °C. Unless otherwise stated data is referred to an ambient temperature of 23°C.

Approvals

With the approval label the independent approval agency and/or test house confirms the compliance with the relevant product standards and/or certain product characteristics.

NOTE: the ordering code structure does allow a large number of possible variations, but not all variations are defined as standard types (ordering codes) and thus some relays may not be included in the list of approved relays. It is recommended that users also seek the pertinent approval files of the agencies/laboratories and review them to ensure that the selected product is filed and meets the requirements. Technical data and approved types on request.

	BEAB	British Electrotechnical Approvals Board, England
	CE	Conformité Européenne, marking for specific products relating to product safety in accordance to European Laws
	CQC	China Quality Certification Center, Peoples Republic of China
	CSA	Canadian Standards Association, Canada
	DEMKO	Danmarks Elektriske Materielkontrol, Denmark
	FIMKO	Sähkötarkastuskeskus Elinspektionscentralen, Finland
	KEMA	Naamloze Vennootschap tot Keuring van, Electrotechnische Materialen, Netherlands
	LLOYD's	Lloyd's Register of Shipping
	NEMKO	Norges Elektriske Materielkontroll, Norway
	ÖVE	Österreichischer Verband für Elektrotechnik, Austria
	SEMKO	Svenska Elektriska Materielkontrollanstalten AB, Sweden
	SEV	Eidgenössisches Starkstrominspektorat, Switzerland
	TÜV	Technischer Überwachungs-Verein, Germany
	UL	Underwriters Laboratories, Inc., USA; UL Component Recognition Mark for the United States
	UL	UL Component Recognition Mark for Canada
	UL	UL Component Recognition Mark for the United States and Canada
	VDE	VDE-Prüfstelle, certificate of conformity with factory surveillance, Germany

Bandwidth

The range of frequencies for which the performance falls within the specified limits.

Bifurcated contact

See > 'Twin contact'.

Bistable relay, latching relay

In a bistable or latching relay the contacts remain in the last switching position once the coil input voltage is disconnected.

Even though the bistable relays are leaving production preferably in reset contact position, the position of the contact (set position/reset position) is not defined at delivery. The user needs to check the contact position and to set/reset the relay to the required position.

Bistable relays only require a short set respectively reset pulse and do not need any energization once the switching position changed. Unless otherwise stated the bistable relays can endure a permanent energization.

NOTE: for some relay series a permanent coil power supply is not permitted; in this case the maximum energization duration or the required coil power reduction is indicated in the respective datasheet.

Bistable relay, switching characteristics

In a bistable relay, the contacts remain in the last switching position after the input voltage is disconnected.

NOTE: unless otherwise stated the position of the contact (set position/reset position) is not defined at delivery, the customer needs to check the contact position and to set/reset the relay to the required position.

NOTE: Unlike monostable relays which return to their predefined contact rest state in case of power supply break down and thus might be showing a fail safe behaviour, bistable relays do not automatically return to such predefined position. Therefore the application and relay control has to be designed to cover such situations and bistable relays should not be used in applications that are rated according to ISO/TS 16949 7.5.3 'Product Identification and Traceability'.

Bounce

An unintentional phenomenon that can occur during the making or breaking of a contact circuit when the contact elements touch successively and separate again before they have reached their final position.

Bounce time

The time from the first to the last closing or opening of a relay contact. Unless otherwise stated the indicated times are maximum values and are for energization with rated voltage, without any components in series or parallel to the coil, and at reference temperature. Also see > 'Relay cycles'.

Breaking capacity max.

Product of the switching current and switching voltage (in W for direct current, in VA for alternating current). Also see > 'DC breaking capacity'.

Bridging contact

Double contact configuration, where two movable contacts are mechanically connected and operate simultaneously. In a bridge configuration, the load current flows from one stationary contact via the bridge to a second stationary contact. See also table 'Contact arrangement'. See > 'Form X contact', 'Form Y contact', 'Form Z contact'.

Definitions (Continued)

Category of protection (IEC 61810)

The 'Relay Technology Categories' (IEC 61810) describe the degree of sealing of the relay case or its contact unit:

- RT 0: unenclosed relay
Relay not provided with a protective case.
- RT I: dust protected relay
Relay provided with a case which protects its mechanism from dust.
- RT II: flux proof relay
Relay capable of being automatically soldered without allowing the migration of solder fluxes beyond the intended areas. These are the contacts, movable parts of the magnetic system and their immediate environment.
- RT III: wash tight (washable) relay
Relay capable of being automatically soldered and subsequently undergoing a washing process to remove flux residues without allowing the ingress of flux or washing solvents.
The test to evaluate the sealing of the case for wash tight relays is performed according to the IEC 60068-2-17, Qc test.

NOTE - Please refer to the 'Processing' section for additional information.

In service this type of relay is sometimes vented to the atmosphere after soldering or washing process; in this case the requirements with respect to clearances and creepage distances can change.

- RT IV: sealed relay
Relay provided with a case which has no venting to the outside atmosphere, and having a time constant better than 2×10^4 s in accordance with IEC 60068-2-17.
- RT V: hermetically sealed relay
Sealed relay having an enhanced level of sealing, assuring a time constant better than 2×10^6 s in accordance with IEC 60068-2-17.

Changeover contact, CO contact

See > 'Form C contact, CO contact, changeover contact'

China RoHS compliance

See > 'Material substance specification' on Tyco Electronics' Website: www.tycoelectronics.com/customersupport/rohssupportcenter/

Clearance distance

Shortest distance in air between two conductive parts or between a conductive part and the accessible surface of the relay.

Coil data

The coil data is specified according to IEC 61810-1.

Unless otherwise indicated the data is given for

- ambient temperature 23°C,
- coil temperature equal to ambient temperature (cold coil, without pre-energization),
- 50Hz for AC supply,
- no other devices (e.g. diode) in parallel or in series to the coil
- single mounting of relays.

Indicated data for the operative range class, is given for the minimum allowed mounting distance.

Unless otherwise stated a duty factor of 100% (permanently operated) is permissible.

Coil insulation system according to UL1446

These requirements cover test procedures to be used in the evaluation of electrical insulation systems intended for connection to branch circuits rated 600V or less. This standard refers to insulation systems and does not cover individual insulating materials.

Coil Operative range (graph)

Admissible range of energizing voltage with respect to the ambient temperature. The upper limit is the maximum coil voltage, the lower limit is the operate voltage U_{min} (coil without pre-energization) and/or the operate voltage U_1 (pre-energized coil).

The diagrams are valid for single mounting of relays without thermal interference and connection wiring according to IEC 61810-1; unless otherwise stated the data is indicated without contact load, thus not taking into account the temperature rise due to the contact current.

The use of a relay with an energizing voltage other than the rated coil voltage may lead to reduced electrical life (mechanical and dynamic effects).

In case the application requires an energization with other than the rated coil voltage and a recommended voltage range is indicated, the coil voltage should be within the recommended voltage range (shaded area) to keep the effects on electrical life to a minimum.

curve 1: operate-/minimal voltage U_0 (without pre-energization)

curve 2: operate-/minimal voltage U_1 (pre-energized coil)

curve 3: maximum voltage at contact current = 0 A

curve 4: limiting voltage U_2 at rated contact current I_{rated}

recommended voltage range (shaded area):

the coil voltage should be within the recommended voltage range to keep adverse effects on electrical life to a minimum.

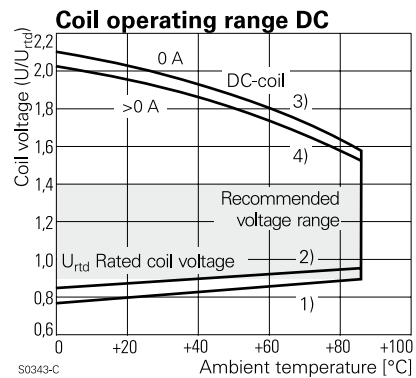

Coil operative range for bistable relays

curve 1: operate voltage at coil temperature equal to ambient temperature

curve 2: minimum reset voltage

curve 3: maximum operate voltage

curve 4: maximum reset voltage

For bistable relays, all curves are given for pulse energization (short energization duration).

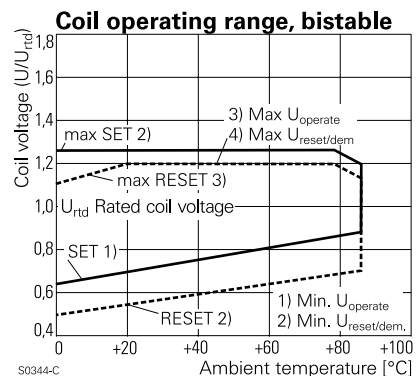

Definitions (Continued)

Coil power

Power consumption of the coil at rated coil voltage and coil resistance, with coil temperature at 23°C, given as rated typical value.

Coil resistance

Electrical resistance of the relay coil at reference temperature; this value is indicated for the coil without any other devices in parallel (e.g. coil suppression, diode, etc.).

Coil suppression circuit

Circuit to reduce the inductive switch off voltage peak of the relay coil (EMC protection, switch off voltage peak). Most of such circuits reduce the armature release speed, which may decrease the relay lifetime, especially valid for diodes in parallel to the coil.

Note: unless otherwise specified the indicated relay data refers to coils without any components in parallel or in series to the coil.

Coil voltage

Voltage applied across the coil terminals.

Coil voltage range

Voltage range at which the relay displays the operating characteristics. These specified operating characteristics are given for a constant DC supply or sinusoidal AC supply. Other operating conditions (e.g. pulse control, ramp voltage, half wave rectifying, etc.) may lead to characteristics other than specified.

Coil-contact circuit data

Insulation parameters between the coil system and the contact circuit/system.

Combination of relay and socket, insulation requirements

The relay standard IEC 61810-1 has an important impact on the combination of a relay and the respective socket. The relay sockets have to comply with the requirements of IEC 61984 and the insulation requirements of the IEC 61810-1. Even if the socket alone fulfills or exceeds the insulation requirements as clearance/creepage for the relay, the combination of a relay with a socket may reduce the creepage and lead to a lower rated insulation voltage. Hence restrictions for the combination relay-socket may be the consequence, e.g. a reduction of the voltage range or of the pollution degree. Especially for miniature multi-pole relay and respective sockets with small distance between the contact circuits, these restrictions have a big impact.

Apart from the insulation properties, the thermal characteristics of the combination relay and socket are of utmost importance (see > 'Derating curves'). As sockets from different sources are not directly comparable, the compliance with the technical specification can only be confirmed for an approved combination relay-socket. As design details and characteristics for non Tyco Electronics products are beyond our control, confirmations for technical parameters and characteristics regarding such combinations is not possible.

Risks as reduced dielectric strength, fire hazard, etc. due to use based on unclear or omitted data, limitations or restrictions must not be underestimated.

NOTE: We only confirm the characteristics and parameters for the approved combinations of relays and sockets as indicated in the catalog and datasheets.

Contact arrangement

Different applications require specific switching functions of the relay contacts; various contact arrangements are specified and described in different ways. The most common are:

	Form description	Short description	NARM designator	Circuit symbol
Make contact	Form A	NO	SPST-NO	
Break contact	Form B	NC	SPST-NC	
Changeover contact	Form C	CO	SPDT	
Double make on armature	Form U		SPST-NO DM	
Double break on armature	Form V		SPST-NC DB	
Double make contact	Form X		SPST-NO DM	
Double break contact	Form Y		SPST-NC DB	
Double break, double make contact	Form Z		SPDT-NC-NO DB-DM	
Triple make contact	Form 3			

Examples for descriptions of multi- pole configurations:

Multi pole configurations	Form description	Short description	NARM designator	Circuit symbol
2 Make contacts	2 Form A	2 NO	DPST-NO	
3 Break contacts	3 Form B	3 NC	3PST-NC	
4 Changeover contacts	4 Form C	4 CO	4PDT	

Contact current

See >

- 'Rated current'
- 'Limiting making current'
- 'Limiting continuous current'
- 'Limiting short-time current'
- 'Limiting breaking current'.

Contact gap

Shortest distance between the open contact points.

Contact material

The list gives an overview of the most important plating- and contact materials and their use in signal-, automotive and general purpose relays.

The switching capacity of the contacts and the respective electrical endurance depends not only on the contact material but also to a high degree on the relay design. Decisive for the application therefore is the optimal combination of the mechanical system and the contact material. The characteristics for certain relay types cannot be transferred to other designs, nor can these values be used as given limits for existing products.

Definitions (Continued)

1) Plating materials:

Fine gold

- best corrosion resistance, not used as solid material because too soft, high tendency towards cold-welding, not used or only used in combination with a material with resistance against cold welding. Gold alloys (AuNi, AuAg, AuPd, AuCo)
- gold platings $\leq 1 \mu\text{m}$ (hv), only as storage protection, no protection against aggressive atmosphere. Hard gold plated (htv)
- very good corrosion resistance, low and stable contact resistance at lowest loads, low tendency to cold welding
- dry-circuit switching (switching without current/voltage), recommended range of application $\geq 1 \text{ V}$, 1 mA, 50 mW.

2) Contact materials:

Silver-Palladium

- high resistance against material transfer in signal DC circuits, low welding tendency, higher contact resistance than Ag
- circuits with medium loads, DC- and AC-circuits, recommended for telecommunication applications.

Palladium-Ruthenium

- highest resistance against material transfer in signal DC-circuits, low welding tendency, higher contact resistance than Ag
- circuits with medium loads, DC- and AC-circuits, recommended for telecommunication applications.

Silver-Nickel AgNi90/10

- high resistance against electrical wear, low welding tendency, higher contact resistance than AgNi0.15
- circuits with medium to high loads, DC- and AC-circuits, recommended range of application $\geq 12 \text{ V}$, 10 mA.

Fine-grain silver AgNi0.15

- relatively low contact resistance, low resistance against aggressive atmosphere
- universally applicable in medium and low load range, especially in DC-circuits, recommended range of application $\geq 12 \text{ V}$, 10 mA.

Silver-Tin-Oxide AgSnO₂

- low welding tendency, high wear resistivity with heavy loads, low material transfer
- circuits with high requirements to make- and break currents, DC- and AC loads, recommended range of application $\geq 12 \text{ V}$, 100 mA.

Tungsten W

- highest melting point, for high switching rates and low ON-time
- as prerun contact in circuits with highest make loads.

Silver-Cadmium-Oxide AgCdO

- compliant with RoHS directive (Directive 2002/95/EC) only under time limited exception, therefore not recommended for new designs
- low welding tendency, high wear resistance
- for switching of inductive loads, AC-circuits, $\geq 12 \text{ V}$, 100 mA.

Contact materials for the use in automotive applications:

Current range	Automotive load type (DC load)	Recommended contact material
Switching and carrying 0.5 A < I < 10 A at 12 V	In low power applications	AgNi0.15 or AgSnO ₂
Periodical switching and approx. 10 ⁶ ops, 1 A < I < 10 A at $\geq 12 \text{ V}$	Long-life indicator switches	AgSnO ₂
Switching and carrying I > 10 A capacitive load	Lamps, Capacitors	AgSnO ₂
Switching and carrying I > 10 A resistive and inductive load	Motors, Valves	AgNi0.15 or AgSnO ₂
Switching high inrush I > 100 A	Lamp (e.g. H4), Spark plugs, short circuit	AgSnO ₂ in special cases: AgNi20 or Tungsten pre-contact

Contact protection circuits

The effect of an electrical arc causes primarily local contact erosion resulting in contact wear and migration and as secondary effect the generation of adverse atmosphere inside the relay (see > 'Electrical arc' and 'Vent hole' in processing section). These effects eventually lead to the end of the useful life of a relay. To reduce the negative effect of the electrical arc and thus prolong the life of a relay, contact protection circuits are recommended. This is especially important for switching of DC applications (e.g. automotive applications). The user has to ensure the correct design of the protection circuit in the respective application, as unless designed correctly, the protection circuit may even generate adverse effects.

Contact rating

In context of our datasheets this term is primarily used in context with ratings as tested/approved by external approval agencies whereas the term 'electrical endurance' is used primarily for internal test results. See > 'Electrical endurance'. Indicated contact ratings for direct wiring of relays (according IEC 61810-1); for relays mounted on sockets or when using connectors deratings may apply.

Contact resistance

Electrical resistance between the relay terminals of a closed contact, measured with indicated measuring current and indicated source voltage. The specified contact resistance is reached reliably only above a particular load. Considerably increased contact resistances can occur with smaller loads. After a prolonged period of a steady state operate/release position or storage of the relay a certain number of cycles are recommended before measurement of the contact resistance.

According to IEC 61810-7 the following measurement parameters are applied (for general purpose relays category CC2 is applicable):

Category	Load		Measurement	
	V	A	V	A
CC0	0.03	0.01	0.03	0.01
CC1	without electrical arc		10	0.1
CC2	with electrical arc		30	1

Contact style

On one side indicates the design of the contact point itself, see >

- 'Single button contact'
 - 'Twin contact, bifurcated contact'
- indicating the contact function, see >
- 'Forcibly guided contact'

as well as the total configuration of the contacts within a relay

- number of poles and
- contact arrangement (see > 'Contact arrangement').

Contact terms

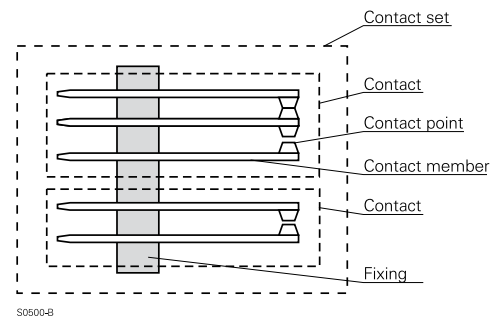

Creepage distance

Depending on the insulation design, usually the shortest distance along the surface of the insulating material between conductive parts according to IEC 61810-1.

Cross talk

Signal interference between adjacent conductors caused by the pick-up of stray energy.

Definitions (Continued)

CTI
See > 'Tracking index'.

Cycle
Operation/set and subsequent release/reset of a relay.

Cycle time
Sum of ON and OFF time (make, break and bounce time) of a contact. See also > 'Duty factor'.

dBm
Relative measure of signal power where the reference 0 dBm is equal to one milliwatt. See also > 'Decibels'.

DC breaking capacity
Switching of loads at voltage and current below the max. DC load breaking capacity curve is possible for a limited number of switching operations, the arc is extinguished. Unless otherwise stated, the indicated curves in the DC breaking capacity diagram represent the load limit curve II (the arc extinguishes within 10ms at resistive load). The breaking capacity curve is affected in both position and shape by the contact material and relay design (contact distance, break speed of the contacts, etc.). No statement on the electrical endurance can be derived from these curves. For practical use it is recommended to keep a distinct margin from the DC load breaking capacity curve.

- Load limit curve (II) The switching arc for loads below this curve extinguishes within 10 ms (the relay is already in release position). Unless otherwise stated the indicated curve for DC breaking capacity relates to the load limit curve II
- Load limit curve (I) The switching arc of loads below this load limit curve extinguishes during the transit time of the moving contact. This limit is especially important for change over relays, when the NC and NO contacts are at different voltage levels; if the arc does not extinguish before reaching the other contact, the arc will establish a short circuit, a situation that may lead to the destruction of the relay and equipment.
- Load limit curve for arc-free switching. Load voltage/current combinations below this load limit curve in general cause no arc or an arc with max. duration of 1ms.

Unless otherwise stated the curves in the graphs refer to a 'load limit curve II'.

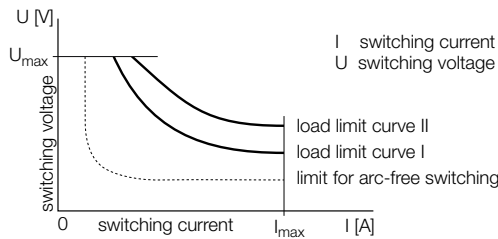

Decibel, dB
A relative and dimensionless unit calculated as ten times the logarithm to the base of 10 of a power ratio.

Degree of protection (IEC 60529)
Degrees of protection provided by enclosures (IP Code) for electrical equipment.

Under certain circumstances this data is relevant for industrial relays and accessories. For relays as components (e.g. PCB relays) the IP classification is generally not used, see > Category of protection; there is no direct correlation between the IP-code and the RT-category, see > Category of protection.

Definition of degree of protection (IP code) IEC 60529 outlines an international classification system for the sealing effectiveness of enclosures of electrical equipment against the intrusion into the equipment of foreign bodies (i.e., tools, dust, fingers) and moisture. This classification system utilizes the letters IP (Ingress Protection) followed by two digits.

Degree of protection - First digit:

The first digit of the IP code indicates the degree that connection is protected against contact with moving parts and the degree that equipment is protected against solid foreign bodies intruding into an enclosure.

- 0 No special protection
- 1 Protection from a large part of the body such as hand or from solid objects greater than 50 mm in diameter
- 2 Protection against objects not greater than 80 mm in length and 12 mm in diameter
- 3 Protection from entry by tools, wires, etc., with a diameter or thickness greater than 2.5 mm
- 4 Protection from entry by solid objects with a diameter or thickness greater than 1.0 mm
- 5 Protection from the amount of dust that would interfere with the operation of the equipment
- 6 Dust-tight.

Degree of protection - Second digit:

Second digit indicates the degree of protection of the equipment inside the enclosure against the harmful entry of various forms of moisture (e.g. dripping, spraying, submersion, etc.)

- 0 No special protection
- 1 Protection from vertically dripping water
- 2 Protection from dripping water when tilted up to 15°
- 3 Protection from sprayed water
- 4 Protection from splashed water
- 5 Protection from water projected from a nozzle
- 6 Protection against heavy seas, or powerful jets of water
- 7 Protection against temporary immersion
- 8 Protection against complete continuous submersion in water (up to 1 meter deep for 15 minutes).

Derating curve (sockets and relay-socket sets)

EN61984:2001 table 12: according to this standard the derating curve given for a specific combination relay-socket and its accessories - indicates the maximum permissible continuous current (limiting continuous current) of a socket, loaded on all contact circuits, unless otherwise stated supplied with rated coil voltage, over the entire temperature range, measured in dense packing (usually 3 relay-socket sets).

In case of reduced duty factor of the contact load or with higher mounting distance up to single mounting, a higher load current is permissible. Please contact our technical support for specific data. According to the standards the derating curve is derived from the measured curve by applying a reduction factor of 0.80.

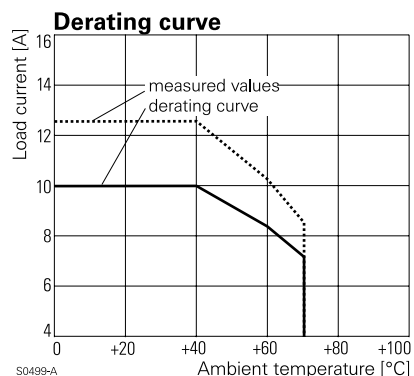

Other standards: the test conditions (e.g. UL508) differ from the EN standard, hence under these conditions other temperature/current combinations may be permissible; please contact our technical support for details.

In case no derating curves are given, the indicated temperature and load current refer to the approved standards for the specific product and not to the EN61984.

Definitions (Continued)

Dimensions

Dimensions are indicated in mm and/or inches and are shown for reference purposes only.
PCB pin dimensions are indicated without solder (pre-tinning).

Dimensions, drawings

Technical drawings for product dimensions are using both ISO projections (ISO Method E or ISO Method A) according to ISO/R 128. In cases of ambiguity the projection is defined by the respective international symbol (see below).

ISO Method E projection - symbol: 

 ISO Method A projection - symbol:

DIN-rail

Unless otherwise stated, our products for DIN-rail mounting are designed and tested for DIN-rails according to TH35-7.5 / EN60175.
Use of other rails (e.g. according to TH35-15) is neither tested nor approved.

When mounting the sockets on a DIN-rail, assembling the socket accessories and mounting/dismounting relays provide an adequate temperature (unless otherwise stated -10°C to +40°C) during the mounting process.

Drop test, free fall

Relays are dropped from a specified height onto a solid ground; this simulates the resistance to bad handling e.g. fall from a table. The test is to verify that the component meets its specification. However we strongly recommend to scrap dropped relays.

Dry switching

Defined as contact category 0 (CO0) according to IEC61810-1: a contact characterized by a maximum contact voltage of 30mV and a maximum contact current of 10mA. See also chapter 'Testing / diagnostics of relays'.

Dust-proof relay

Relay with a case to protect against penetration of dust. See > 'Category of environmental protection (IEC 61810)' - RT I.

Duty factor, duty cycle

Ratio of the duration of energization to the total period in which intermittent or temporary operation of the relay place. Duty factor is expressed as percentage of the total period at a specified frequency of operation; e.g. 30% duty cycle means that the relay is operated for 30% during a cycle time.

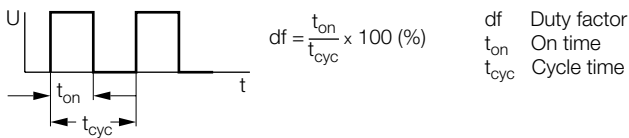

Electrical arc

Is an electric phenomenon caused by plasma current flow between opening and closing relay contacts. An arc is generated by the electric energy of the load circuit (turn off spark) or the voltage gradient at closing contacts, ionizing the gas between the contacts and thus establishing an electrical conductive path. The stability of the arc depends on various parameters such as contact material, air pressure, contact gap, etc.

Apart from positive effect of the electrical arc as limitation of overvoltage when switching of inductive loads, reduction and dissipation of electrical load energy and electrical cleaning of contact surfaces, the arc locally produces high temperature and causes contact erosion (also see > 'contact protection circuits'). Special consideration has to be given to DC and high frequency AC-circuits where, depending on the conditions (e.g. contact gap) an arc of extended or infinite duration could occur; in this case the relay may be destroyed due to the extreme thermal stress. Also the switching of different voltages with a generation of an electrical arc and the switching of reverse polarity on adjacent contact circuits of a multi-pole relay may lead to non-extinguishing arcs.

Electrical endurance

Number of cycles a relay can perform with electrical contact load defined under specified conditions according IEC 61810-1 and IEC 61810-2. Unless otherwise specified the electrical endurance refers to:

- NO contact
- AC mains, 50 Hz for general purpose relays (schematic for contact loading A) ; 12 VDC for automotive relays
- duty factor 50%
- rated frequency of operation
- resistive load
- rated voltage (coil)
- ambient temperature 23°C
- category of protection RTII - flux proof
- individual mounting of relays without thermal interference and connection wiring according to IEC 61810-1, table 12.
- relay in upright position (terminals of a print relay pointing downwards).
- direct wiring of relays (according IEC 61810-1); for relays mounted on sockets or when using connectors deratings may apply.

Unless otherwise stated, the electrical endurance is specified according to severity level B according IEC 61810-2. For relay failure modes see also > Failure criteria. Any use beyond the specified electrical endurance is not in scope of the specified data, the avoidance of such situation requires consideration by the user.

Electrical endurance graph

The electrical endurance graph indicates the typical electrical endurance with resistive load and 250 VAC rated voltage as "Mean Cycles to Failure" (MCTF) according Weibull distribution. These statistical data do not guarantee a minimum value; this data can be used to estimate the MCTF value. Please note:

- the graph for electrical endurance is only valid for the indicated contact material (in case no contact material is specified, it is valid for the contact materials as listed in the respective datasheet), it is not permissible to deduce electrical endurance information for other contact materials.
- it is not permissible to deduce electrical endurance information by extrapolation beyond the range indicated by the curve. This applies especially to the range below 0.5 A as at this level the contact wear is small and other failure modes are dominant.

For details please contact our technical support. Also see > 'Electrical endurance'.

ELV compliance

See > 'Material substance specification' on Tyco Electronics' Website: www.tycoelectronics.com/customersupport/rohssupportcenter/

Endurance

Electromechanical components as relays, are subject to wear (mechanical and electrical). For the reliability the typical bath-tub curve applies, hence singular statistical failure events below typical reliability values may occur.

Environmental data and tests

Relays undergo extensive environmental tests. The selection of tests depends on the product group and the intended application fields; e.g. for automotive relays, common environmental tests are:

- cold storage test, IEC 600 68-2-1
- dry heat, IEC 600 68-2-2
- climatic cycling with condensation. EN ISO 6988
- temperature cycling, IEC 600 68-2-14 Na (shock), IEC 600 68-2-14 Nb
- damp heat cycling, IEC 600 68-2-30 Db variant1
- operational humidity, IEC600 68-2-38
- corrosive gas, IEC 600 68-2-42
- flowing mixed gas corrosion, IEC 600 68-2-60 Ke method 54
- drop test, free fall, IEC 600 68-2-32.

Environmental endurance

Generic term for the relay endurance under different climatic conditions. Appropriate test conditions are classified in IEC 60068.

Definitions (Continued)

Failure criteria

Set of rules used to decide whether an observed event constitutes a failure. A contact failure is the occurrence of break and/or make malfunctions of a contact under test, exceeding a specified number.

Failure mode

The IEC 61810 defines a relay failure as occurrence of malfunctions, exceeding a specified number:

- malfunction to make
- malfunction to break (contact bridging on a CO contact as a special form of malfunction to break), or as
- insufficient dielectric strength.

Such malfunctions have to be taken into consideration and must not generate risks. Depending on the specific load, its characteristics and power in the contact set, a relay malfunction situation may generate various risks such as malfunction of the equipment and its controls, electrical shock, the risk of excessive heat and fire and others. It is in the responsibility of the user to provide for additional precautions against such possible effects according to the relevant application standards.

Standards (e.g. IEC 695-1-1 'Guidance for assessing fire hazard of electro-technical products') are based on the principal assumption of heating effects and risk of fire in case electrical currents of certain magnitude being conducted and switched. Our relays are manufactured with self-extinguishing plastics corresponding to the up-to-date technology and standards requirements. Protection against excessive heat and possible spread of fire under all operation conditions even in case of malfunction can only be ensured by the design of the equipment as well as by application instructions for the end user; it is the responsibility of the manufacturer of the equipment to take the appropriate measures. Incorrect connections by the user may lead to risks, faulty operation and abnormal heating or fire. It is also the responsibility of the manufacturer of the equipment to take appropriate measures to avoid potential danger of electrical shock by preventing access to live parts of the relay including parts as terminals and accessories.

Flux proof/suitable for processing on soldering lines

See > 'Category of environmental protection (IEC 61810)' - RT II.

Force guided contact

Contact configuration according to EN 50205 with at least one NO contact, one NC contact and a mechanically linked system, designed that the NO and NC contacts within the complete contact set are never closed at the same time, even in case of malfunction. These relays are implemented in the control of safety technology for the protection against damage to persons or objects.

See > 'Relays with force guided contacts'.

Form 3 contact, triple make contact

Three make contacts configuration with three electrically connected movable contacts operating simultaneously. There is no external connection to the armature. See also table 'Contact arrangement'.

Form A contact, NO contact, normally open contact

A contact that is open when the relay is in its release condition (unenergized position for monostable relays) and which is closed when the relay is in its operate condition. For circuit schematic see table 'Contact arrangement'.

Form B contact, NC contact, normally closed contact

A contact that is closed when the relay is in its release condition (unenergized position for monostable relays) and which is open when the relay is in its operate condition. For circuit schematic see table 'Contact arrangement'.

Form C contact, CO contact, changeover contact

Compound contact consisting of Form A (NO, make) contact and a Form B (NC, break) contact with a common terminal. On changing the switch position, the contact previously closed opens first followed by the closing of the contact that was previously open. For circuit schematic see table in 'Contact arrangement'.

Note: in case of a switching arc the NO and NC contact may be temporarily electrically connected.

Form U contact

Two make contact configuration, with two electrically connected movable contacts which operate simultaneously. As special version main contact with pre-contact. See also table 'Contact arrangement'.

Form V contact

Two break contact configuration, with two electrically connected movable contacts which operate simultaneously. See also table 'Contact arrangement'.

Form X contact

Two make contact configuration with two electrically connected movable contacts operating simultaneously. There is no external connection to the armature. Also called bridge contact.

Form Y contact

Two break contact configuration with two electrically connected movable contacts operating simultaneously. There is no external connection to the armature. Also called bridge contact.

Form Z contact

A contact configuration with

- two make contacts and
- two break contacts

with two electrically connected movable contacts each operating simultaneously. There is no external connection to the armature. Also called bridge contact.

Frequency of operation

Number of operation cycles (opening and closing of contacts) per unit of time. The switching rate is usually indicated for switching under rated load; unless otherwise stated at ambient temperature 23°C and without any circuitry in parallel to the coil (no coil suppression circuit, e.g. diode). With contact loads considerably below rated load a higher frequency of operation may be admissible. This has to be tested for the specific application. For further assistance please contact our application support.

Full disconnection

Contact separation for the disconnection of conductors so as to provide the equivalent of basic insulation between those parts intended to be disconnected. NOTE: there are dielectric strength and dimensional requirements regarding the relay design but also referring to the connection, wiring and design on the outside of the relay.

Halogen content

See > 'Material substance specification' on Tyco Electronics Website: www.tycoelectronics.com/customersupport/rohssupportcenter/

Immersion cleanable/sealed relays

See > 'Category of environmental protection (IEC 61810)' - RT III.

Relays which are sealed against the penetration of specified PCB cleaners or protection lacquers; for more information refer to chapter 'Processing Information'.

Impedance, Z₀

Characteristic property of a transmission line describing the ratio between electric and magnetic fields.

Industrial relays and accessories

Relays and accessories are designed for use in closed and electrically secure switching cabinets. In these applications lower standard requirements of the insulating properties of components could apply.

CAUTION: These products are to be handled by trained personnel only.

Initial contact resistance

Contact resistance measured at the time of production/final testing. Prolonged storage and adverse environmental conditions (e.g. gases) can lead to increased resistance values. The effect of electrical cleaning due to sufficient load can bring the contact resistance back to lower levels.

See > 'Contact resistance'.

Definitions (Continued)

Initial dielectric strength

Voltage (rms value in AC voltage, 50 Hz 1 min) the insulation can withstand between relay elements that are insulated from one another, measured at the final production test.

Initial insulation resistance

Electrical resistance (initial product condition) measured by applying a DC voltage of 500 V between two elements of a component that are insulated from one another as measured at the final production test.

The requirements according to IEC 61810-1 are:

- for functional insulation > 2 MOhm
- for basic insulation > 2 MOhm and
- for reinforced insulation > 7 MOhm.

Initial pulse withstand voltage, initial surge voltage resistance

Amplitude of a voltage impulse of short duration with a specified impulse form (e.g. 1.2/50µs) and polarity applied to test insulation paths in a relay, especially where relays are subject to overvoltage situations (e.g. effects of lightning).

Insertion cycles

The symbol A indicates that the insertion and extraction must be done without any load current on the relay/socket contacts.

Unless otherwise stated the accessories are designed for max. 10 insertion cycles, insertion and extraction without load; A (10).

Insertion loss

The loss in load power due to the insertion of a component at some point in a transmission system. Generally expressed in decibels as the ratio of power received at the load before insertion of the apparatus to the power received at the load after insertion.

Insulation

Unless otherwise stated, the insulation characteristics are indicated for the relay component, the design of the application, mounting and wiring also has to provide for required insulation properties.

In general, the relays are designed to be used within enclosures; the relay surfaces are not to be accessible for direct contact by the end user. Specific insulation requirements of the equipment and protection against environmental effects need special consideration.

Jump start test

Short time relay use at higher system voltages (like car start after flat vehicle battery).

Latching relay

See > 'Bistable relay'.

Limiting breaking current

The max switching current the contact is intended to break under specified load conditions. The switching current must not exceed the indicated rated current.

For DC switching also see > 'DC breaking capacity'.

Limiting continuous current

Is the highest steady state load current a relay or an accessory can withstand continuously while satisfying specified temperature rise requirements; it is identical with the limiting continuous thermal current I_{th} .

NOTE that this is not necessarily the current that can be switched over the specified lifetime. Unless otherwise stated the data for relays is given under following condition: all contacts equally loaded with the respective current, input voltage 110% of nominal coil voltage, max ambient temperature, minimum allowed mounting distance, test conditions according to the heat test arrangement IEC EC 61810-1 Annex B. In combinations with accessories/sockets the limiting continuous current is specified by the derating curve (see > 'Derating curve').

Limiting making current, inrush current

The limiting making current expressed as a current with a power factor of 1.0 (resistive load) a contact is able to make under specified conditions; for 20 ms data expressed as peak value, for 4 s data expressed as rms value. Unless otherwise stated the data refers to the Form A contact (NO contact), rated voltage and a current for a duration of max. 20 ms for at least 100 cycles or 4 s with duty factor of 10%.

Inrush current for some loads can be significantly higher than its specified steady state current. For these load types the inrush current has to be within the limits for the limiting making current. Typical examples for loads with high inrush currents are all type of lamps (incandescent, halogen, fluorescent, etc.) as well as motors, solenoids, transformers and capacitive loads.

Limiting short-time current, Overload current

This test is done to confirm, that our relays withstand normal overload conditions, e.g. withstand short circuit conditions until a fuse opens.

For automotive applications, current and time are compatible to circuit protection by a typical automotive fuse according to ISO 8820-3 (2002) as shown in the table below. Relay will carry the specified currents at 23°C (I_{rated} = rated current as given in contact data section for each relay).

Test current in A	Operating time in seconds	
	Minimum	Maximum
6.00 * I_{rated}	0.02 s	0.20 s
3.50 * I_{rated}	0.08 s	0.50 s
2.00 * I_{rated}	0.25 s	5.00 s
1.35 * I_{rated}	0.75 s	1800 s
1.10 * I_{rated}	100 h	No requirement

For mains fuses and fuses other than automotive, customers have to refer to the respective standards (mains condition, prospective short circuit, etc.) to test for their application.

Limiting voltage (coil)

The highest permissible input voltage (coil voltage) at the reference temperature at which the relay, with continuous energization and, unless otherwise stated under rated contact load, heats up to its max. permissible coil temperature.

Load dump

Short relay use at overvoltage (disconnection of the battery during running engine).

Load dump test

Short relay use under overvoltage conditions (simulated disconnection of the battery with charging alternator).

Magnetic system

Magnetic systems can be categorized by the switching characteristic

- monostable relays return automatically to the rest position (release state) after the coil is de-energized.
- bistable relays maintain their switching position after the energization or input voltage is disconnected. See > bistable relays and the design of the magnetic circuit:
 - neutral (non-polarized) relays operate independently of the polarity of the applied voltage (coil voltage)
 - polarized relays use an additional magnet within the magnetic circuit and therefore only operate with a specific polarity of energization.
 - remanent bistable relays adopt a particular switching position following an energizing direct current in any direction and are then held in this position by the remanence in the magnetic circuit.

Make-before-break contacts

Contact mechanism where Form A contacts (normally open contacts) close before Form B contacts open (normally closed contacts).

Definitions (Continued)

Material group of insulation parts

Categorization of insulation materials according to their tracking indices, according to IEC 60664-1.

Material substance specification

For material information regarding ELV, China RoHS compliance, European RoHS compliance, Halogene and REACH refer to product specific information on Tyco Electronics' Website: www.tycoelectronics.com/customersupport/rohssupportcenter/

Max. coil power

The highest permissible input power at the reference temperature at which the relay, with continuous energization, heats up to its max. permissible coil temperature. Unless otherwise stated the data is indicated without contact load.

Max. coil temperature

As general term refers to the max. approved coil temperature, measured by change of resistance method.

UL classifies max. coil temperatures according to UL1446; this standard refers to insulation systems and does not cover individual insulating materials:

- class B - max. 130°C
- class F - max. 155°C.

Max. insertion force total

The force during the insertion of the relay into the socket has to be applied in insertion direction (no tilting) and equally on all connections. The maximum applied force must not exceed the indicated max. insertion force.

Max. operate/reset duration

Maximum duration a bistable coil may be energized with rated DC voltage.

Max. switching voltage

Maximum voltage that may occur between the switching contacts before closing or after opening the contact. Data given for AC refer to V_{rms} in a mid-point earthed 3-phase supply system.

Maximum energization duration

Maximum duration a coil may be energized with rated DC voltage; energization beyond the indicated duration will overheat of the coil system and the relay.

Maximum voltage (coil), U_{max}

The highest permissible input voltage (coil voltage) at the reference temperature at which the relay, with continuous energization and without contact load, heats up to its max. permissible coil temperature. Also see > 'Limiting voltage'.

MCTF - Mean cycles to failure

Expected value of the distribution of operations to failure, average number of operations according to Weibull.

Mechanical endurance

Number of cycles without contact load during which the relay remains within the specified characteristics.

NOTE that the failure criteria for mechanical endurance are not the same as for electrical endurance, therefore the value for mechanical endurance has no relation and cannot be directly compared to electrical endurance for very low loads!

Mechanical life

See > 'Mechanical endurance'.

Minimum energization duration

Minimum duration the coil needs to be energized with rated DC voltage. Unless otherwise stated the proposed minimum energization duration is 100 ms.

Minimum recommended contact load

The minimum contact load a relay can reliably switch/carry depends on the relay design and used materials; there is no physical limit as for the definition of a minimum switching voltage or current. The indicated value is a recommendation, it is influenced by switching frequency, required contact resistance and its stability over time and ambient conditions. Low contact resistance is reached reliably only above a particular load, considerably increased contact resistance can occur with lower loads.

- Signal relays are capable to carry and switch minimum contact loads in the range of the thermoelectric potential which is approx. 100µV.
- General purpose relays are designed for category CC2 loads according IEC61810; basically these relays are designed for switching loads with the effect of switching arcs. Specific insulation requirements however may call for the use of general purpose relays in applications with low signal loads or for dry switching (switching without the generation of an electrical arc). NOTE that increased contact resistance may occur if the load conditions are not in scope of the test conditions for category CC2 according IEC61810. Also see the minimum contact loads recommended for the different contact materials.
- Automotive relays usually are switching higher DC loads with switching voltages above the fritting voltage and with switching power within the contact cleaning effect of an electrical arc.

Minimum recommended switching power

Product of switching current and switching voltage for reliable switching. Low contact resistance is reached reliably only above a particular load, considerably higher contact resistances can occur with smaller loads.

Minimum set/reset duration

Minimum duration a bistable coil needs to be energized with rated DC voltage.

Minimum voltage (coil)

For

- monostable relays see > 'Operate voltage'
- bistable relays see > 'Set voltage' and 'Reset voltage'.

Monostable, neutral relay, non-polarized relay, polarized relay

A relay is called monostable when its contacts return automatically to the rest position (release state) after the coil is de-energized.

Non-polarized relays operate independently of the polarity of the applied voltage (coil voltage) whereas polarized monostable relays only operate with a specific polarity of energization.

Mounting

Describes specific mounting options of the relay. See >

- 'Through-hole-technology (THT)'
 - 'Through-hole-reflow (THR)'
 - 'Surface mount technology (SMT)'
 - for Mounting on DIN-rail (relays and accessories) see > 'DIN-rail'.
- See also > 'Mounting' in the processing section.

Mounting distance

The distance between two adjacent relays in parallel and unidirectional mounting according to IEC 61810-1 or distance to other electrical components including the pc-board. Insulation requirements may stipulate an increase to the minimum distance between the relays or to choose a different placement.

If not otherwise stated the product data refers to relays in 'single mounting'.

In addition to this definition we use:

- dense packing: relays mounted at minimum distance; this minimum distance is defined by the requirements of the insulation coordination at rated voltage 230 VAC, and/or by mechanical requirements for the mounting of the relay (e.g. use of sockets)
- single packing: relays mounted at a distance without any thermal impact of adjacent relays or components.

Definitions (Continued)

Mounting position / Placement

Unless other restrictions are stated the relays can be mounted in any direction. The relay connections have to be fully contacted and with adequate cross-sections to ensure the current flow and heat dissipation. For the arrangement of the relays the insulation requirements, heat dissipation and the magnetic interrelation have to be taken into consideration.

MTBF - Mean cycles between failure

Expected value of the distribution of operations between failure. For components with limiting failures due to wear (e.g. contact wear), see > 'MCTF-Mean cycles to failure'.

Nominal power (coil)

See > 'Rated coil power'.

Nominal voltage (coil)

See > 'Rated coil voltage'.

Normally closed contact, NC contact

See > 'Form B contact, NC contact, normally closed contact'.

Normally open contact, NO contact

See > 'Form A contact, NO contact, normally open contact'.

Open contact circuit data

Insulation parameters of the contact circuit.

Operate

Process in which a relay shifts from the release/rest condition to the operate condition.

Operate state, operate condition

For a monostable relay, specified condition of the relay when it is energized by the specified energizing quantity and has responded to that energization. For a bistable relay, it refers to the condition other than the release/reset condition as declared by the manufacturer.

Operate time (DC coils)

The time interval that elapses from energizing a monostable relay in the rest state with the rated voltage (pulse or square signal) at an ambient temperature of 23°C to the moment when the last output circuit is closed or opened (bounce time not included). The operate time varies with the applied coil voltage and the ambient/coil temperature.

This definition refers to DC-coils only, due to the dependency of the phase angle considerably longer operate times may occur with AC magnetic systems.

Operate voltage

Value of coil voltage at which a monostable relay operates. For bistable relays see > 'Set voltage'.

Operate voltage U_1

Value of the coil voltage at which a relay operates, having previously been energized at the same voltage and with rated contact load (thermal equilibrium has to be achieved).

Operate voltage without preenergizing U_0

Minimum permissible input voltage at which the relay operates, for a coil temperature equal to the reference temperature (23°C coil temperature without preenergizing).

Operation

One switching cycle including energizing and de-energizing of the relay coil.

Operative range

According to IEC 61810-1.

Class 1: 80%..110% of the rated coil voltage (or range)

Class 2: 85%..110% of the rated coil voltage (or range)

For diagram specification see > 'Coil operative range'.

Packaging unit

Minimum delivery quantity (e.g. per carton/plastic bar) and quantity per box. Additionally, minimum quantity requirements apply and these requirements may differ from indicated packaging units. Please consult with your Tyco Electronics sales organization or authorized distributor.

PCB

Printed circuit board.

Peak inrush current

See > 'Limiting making current'.

Pre-contact, pre-make contact

Contact with two operating contact points usually of different material, with one contact switching prior to the other one. Pre-make contacts are used mainly for high inrush currents.

Product code

The ordering code structure does allow a large number of possible variations, but not all possible variations are defined as standard types (ordering codes) and thus not included in the product range. Special versions to customer specifications can be supplied. Please contact your local sales organization.

Product date code

Printed on the product. Indicates the date of production of the product; the most common format is 'year+week', 'yymm' (e.g. 0412 indicates production in 2004 week 12); this code may be followed by additional related information.

Product marking/specials



'Caution' - this symbol indicates a general possible cause of risk - refer to the specification/data sheet for details.



'Read instructions' - this symbol refers to important information in the respective data sheets or specification



Symbol for a NO contact



Symbol for a NC contact



Symbol for a CO contact



Symbol for a forcibly guided contact set



Symbol for coil information

For information on production date code see > 'Product date code'.

Protection class

See > 'Degree of protection (IEC 60529)'.

Protection to heat and fire

Data of the flammability class according to the UL 94 (Underwriters Laboratories, Inc., USA) specification.

UL 94 flammability testing, conducted on plastic materials to measure flammability characteristics, determines the material's tendency either to extinguish or to spread the flame once the specimen has been ignited. According to IEC61810-1, all plastic materials have to fulfil the Glow Wire test requirements with min. 650°C.

PTI

See > 'Tracking index'.

Definitions (Continued)

Push-to-test button, test tab

For manual operation of the relay. The test button is to be used for test purposes of an equipment or installation. The push-to-test button is not designed for standard ON/OFF operations, for continuous electrical operation in the manually set ON state, and is not to be used as a switch. Before operating the test tab, the operator has to make sure that the load and any other connected item will operate safely. As safety functions of the equipment might be bypassed and reduced insulation requirements apply, the test button is to be operated by trained personnel only.

Quick connect terminals (spade terminals)

The connectors indicated in the datasheet may be used for the connection to the relay. When using this connector type the given plug cycles and the maximum permissible current have to be taken into consideration. The connector and wire cross section have to be selected so that under the current load the increase of the temperature at the connector point must not exceed 45 K. For high contact currents it is recommended to solder the connection. Furthermore the correct insulation of the connectors/plugs have to be respected.

Rated coil power

Product of coil current and voltage at rated coil voltage (in mW or W for DC-coils and in VA for AC-coils)

Rated coil voltage, Nominal voltage (coil)

Rated voltage at which the relay displays the operating characteristics, given for a constant DC supply or sinusoidal AC supply. Other operating conditions (e.g. pulse control, ramp voltage, half wave rectifying, etc.) may lead to characteristics other than specified.

Rated current

Current a relay can switch on and off and a relay or accessory can carry under specified conditions. Unless otherwise defined the rated current covers:

- contact current, switching current
- limiting continuous current: For a relay the specified conditions are defined under contact ratings; see > contact ratings. For accessories the rated current is specified for a duty factor of 50% at rated frequency of operation and at ambient temperature 23°C; the respective derating curves should be followed.

Rated values

Standard values the relay is designed for. Values are used to classify relays.

Rated voltage (contacts)

Voltage between the switching contacts before closing or after opening of the contact.

REACH SvHC compliance

See > 'Material substance specification' on Tyco Electronics Website: www.tycoelectronics.com/customersupport/rohssupportcenter/

Reference temperature

Unless otherwise indicated the reference temperature refers to an ambient temperature of 23°C ('room temperature'). Also see > 'Coil data'.

Reference values

Reference values for all tests according to IEC 61810-1.

Reflection loss, Return loss

The part of a signal which is lost due to the reflection of power at a line of discontinuity.

Reinforced insulation

A single insulation system applied to live parts which provides a degree of protection against electric shock, comparable to a system comprising basic insulation and supplementary insulation (refer to IEC 61810-1, Type of insulation).

Relay cycles

Due to the self induction of the coil and the inertia of the parts to be moved, on activating a relay the operations do not take place suddenly. The function diagram below shows the different cycles for the most important relay configurations of undelayed power relays. Unless otherwise stated the indicated times are maximum values, the cycles specified apply to DC-coils energized with rated voltage (without any components in series or parallel to the coil) and at the reference temperature.

See

- 'Operate time'
- 'Release time', 'Reset time'
- 'Bounce time'
- 'Minimum energization duration'

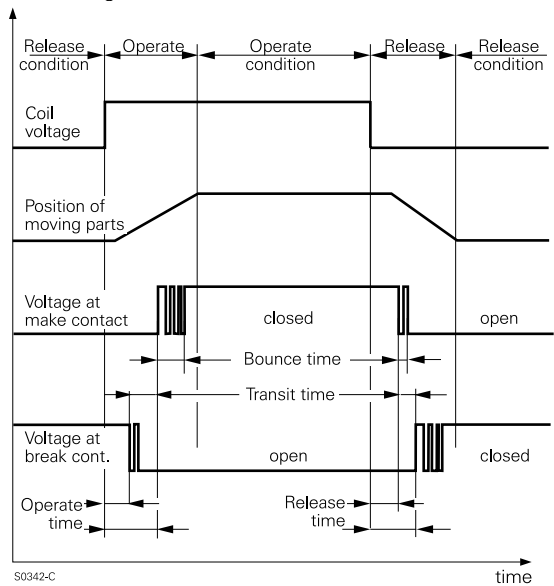

Relay with force guided contacts

The compliance with regulations for the safety of persons and material is imperative in our technical world. National and international regulations take various risks into account. These safety standards also make demands on components which share with their function the safety level of a plant, machine or the equipment. For relays being used for safe contact monitoring purposes the contacts have to be linked mechanically in a way, that NO and NC contacts must not be closed at the same time. It has to be ensured, that over the entire life and even in case of malfunction (e.g. contact welding) the open contact gap will be at least 0.5 mm. Relays with force guided contacts comply with the requirements of EN 50205.

Release

Process in which a monostable relay shifts from the operate state back to the rest state.

Release state (normal position)

Switch position of a non-energized monostable relay.

Release time

The time interval that elapses from the point of time at which a monostable relay in the operating state has the rated voltage disconnected to the point of time at which the last output circuit has closed or opened (not including the bounce time). Unless otherwise stated the indicated times are maximum values and are valid for energization with rated voltage, without any components in series or parallel to the coil, and at reference temperature.

Release voltage

The input voltage at or below which a monostable relay releases to the rest state at the reference temperature.

Definitions (Continued)

Reliability

Electromechanical components as relays, are subject to wear (mechanical and electrical). For the reliability the typical bath-tub curve applies, hence singular statistical failure events below typical reliability values may occur.

Reset

Process in which a bistable relay returns from the operate state back to the rest state.

Reset state

Switch position of a bistable relay as specified by the manufacturer. Unless otherwise stated the reset state is the contact position where the normally open contacts (form A, NO contact) are open and the normally closed contacts (form B, NC contact) are closed. Please note that the contact position for bistable relays is not defined at delivery.

Reset time

The time interval that elapses from the point of time at which a bistable relay in the operating state has the rated voltage (applied in the opposite direction for 1-coil systems and to the reset coil for 2-coil systems) to the point of time at which the last output circuit has closed or opened (not including the bounce time).

Reset voltage

The input voltage to a bistable coil for reset to the rest state at the reference temperature. Please note the wiring diagram and the polarity (see > 'Bistable relay').

■ Reset voltage max.

The input voltage that must not be exceeded to a bistable coil for reset to the rest state at the reference temperature.

■ Reset voltage min.

The input voltage that has to be applied to a bistable coil for reset to the rest state at the reference temperature.

Resistance to soldering heat

According to IEC 60068-2-20, method 1A.

Rest state

Switch position of a monostable relay in the unenergized state. For bistable relays see> 'Reset state'.

RoHS - Directive 2002/95/EC, EU RoHS compliance

Directive on the Restriction of Hazardous Substances (Directive 2002/95/EU, RoHS directive) restricting the use of certain materials as Lead (Pb), Cadmium (Cd), Mercury (Hg), hexavalent Chromium (Cr6), polybrominated Biphenyls (PBB) and polybrominated Diphenylethers (PBDE).

'Compliant'

indicates that the entire product group is compliant with the RoHS directive and none of the above materials is intentionally added and/or below the limits set forth in the directive.

'Compliant versions'

indicates that certain products within the respective product group are compliant with the RoHS directive. The RoHS compliant selection is indicated together with the information on the RoHS compliance. Some products of that product group however do contain materials (e.g. Cd) listed above and thus are not compliant with the RoHS directive.

Safety relay

See > 'Relay with force guided contacts'.

Sealed relay

See > 'Category of environmental protection (IEC 61810)' - RT IV and RT V.

Set time

The time interval that elapses from operating a bistable relay with the rated voltage (pulse or square signal) at an ambient temperature of 23°C to the moment when the last output circuit is closed or opened (bounce time not included). The operate time varies with the applied coil voltage and the ambient/coil temperature.

Set voltage

Value of coil voltage at which a bistable relay operates. For monostable relays see > 'Operate voltage'.

Shock resistance (destruction)

This test is used to evaluate the resistance of the relay to heavy mechanical shocks leading to a permanent damage to the relay. This test is performed according to the IEC 60068-2-27, Ea test.

Shock resistance (function)

This test is used to evaluate the resistance of the relay to mechanical shocks such as those that could occur in transport or during operation (no opening of closed relay contacts with a duration >10 µs). This test is performed according to the IEC 60068-2-27, Ea test.

Data valid for all relay axes unless otherwise stated. Nevertheless it is recommended to avoid shock especially in armature and contact movement direction.

Single contact

Contact system with one contact point per contact member (contact blade).

Single/double throw contact

A single throw contact connects one common line (movable contact) to one load line (stationary contact). See > 'Form A contact' and 'Form B contact'. A double throw contact switches one common line between two stationary contacts, for example between a NO contact and a NC contact. See > 'Form C contact, CO contact, changeover contact'.

Single/double/multi pole

A single pole relay connects one common line (movable contact) to one load line (stationary contact).

A double pole relay switches two, electrically disconnected common lines with two electrically independent load lines (like two separate make relays); the same stands for multi-pole relays, the number of poles indicate the number of independently switches load lines.

Switching of different potentials on adjacent contact circuits of a multi-pole relay is permitted as long as the sum of applied voltages does not exceed the rated insulation voltage.

The switching of different voltages with the generation of an electrical arc and the switching of reverse polarity on adjacent contact circuits of a multi-pole relay without contact separated chambers however is not permitted. The contact load has to be connected to the same contact side.

Sockets and accessories

All listed sockets and accessories have been tested and approved only with the indicated relays from the Tyco Electronics product range.

For combinations of sockets with other relays with similar design and pinning Tyco Electronics cannot take responsibility for any malfunction. Also see > 'Combination of relay and socket'.

Soldering temperature/time, IEC 60068-2-20

See > 'Resistance to soldering heat'.

Solid insulation

Solid insulating material between two conductive parts.

Steady state current limit

See > 'Limiting continuous current'.

Stripline

A type of transmission line configuration which consists of a single narrow conductor parallel and equidistant to two parallel ground planes.

Switching capacity

See > 'Switching power'.

Definitions (Continued)

Switching current

See >

- 'Rated current'
- 'Limiting making current'
- 'Limiting breaking current'.

Switching power

Product of the switching current and switching voltage (in W for direct current, in VA for alternating current).

Switching rate

See > 'Frequency of operation'.

Switching voltage

See > 'Rated voltage (contacts)'.

Switching voltage max.

See > 'Max. switching voltage'.

Terminal assignment

For historical reasons and due to typical application nomenclature (e.g. relays in automotive applications) different terminal assignment schemes are used: Terminal assignment to IEC 67

The terminals are identified by consecutive numbers. Please note that two digit identifiers exist in both the IEC 67 and the EN 50005 identification systems and may have different meaning.

Terminal assignment to EN 50005: the terminals are defined by a two digit code:

- for the coil terminals 'A1', 'A2' are used
- for contacts the first number indicates the pole, the second number indicates the function
- 1 for the movable form C, CO contact,
- 2 for the form B, NC contact,
- 4 for the form A, NO contact
- e.g. a terminal '24' indicates the form A, NO contact of the second pole of a relay.

Automotive relays

Quick connect style coil and load terminals ISO relays may be numbered according to two different standards, the terminals have the same location and function. The respective numbers are:

- 1 or 86 for the first coil pin;
- 2 or 85 for the second coil pin;
- 3 or 30 for the common load pin;
- 4 or 87a for the form B, NC load pin;
- 5 or 87 for the form A, NO load pin.

NOTE that the terminal assignment graphs are indicated either 'bottom view' (as seen from the solder wave side of pcb's, pin side of the relays) or 'top view' (as seen from the component side of single sided pcb's or the cover side of a relay).

Terminal torque, screw type terminals

For screw type terminals the maximum indicated screw torque must not be exceeded.

No torque must be applied to any other terminal types of relays or accessories.

Test voltage/dielectric test voltage/dielectric strength

Voltage applied during dielectric (high voltage) tests between intentionally not electrically connected parts of the relay.

Thermal resistance

Relay parameter measured in Kelvin per Watt, which relates the consumed power with the respective temperature increase in the state of thermal equilibrium measured without load and without components in parallel or in line to the coil. Multiplied with its power consumption (at the actual coil temperature) it indicates the temperature rise of the coil above ambient temperature.

Thermoelectric potential

Voltage at the relay terminals of a closed contact resulting from a temperature difference of the different metal junctions (terminal, spring, contacts,...) inside the relay.

Through-hole reflow (THR)

An assembly process, where THT components are soldered in a reflow process instead of traditional wave soldering (also referred to as pin-in-paste). For details see chapter Processing Information.

Through-hole technology (THT)

An assembly process for mounting components where terminals are passed through supported (plated through) or unsupported (bare) holes in an inter-connection substrate. Normally, traditional wave soldering is used with THT components.

Tracking

Progressive degradation of a solid insulating material by local discharges to form conducting or partially conducting paths.

Tracking index

- PTI - Proof tracking index - numerical value of the proof voltage expressed in volts which a material in test can withstand without tracking under specified conditions (according IEC 212-01-45).
- CTI - Comparative tracking index - numerical value of the maximum voltage expressed in volts which a material in test can withstand without tracking under specified conditions (according IEC 212-01-45).

Transit time

The movement time of the armature after opening of one contact set (e.g. NC) before closing of the other (e.g. NO) of a changeover relay. See > 'Relay cycles'.

Twin contact, bifurcated contact

Contact with two simultaneously operating contact points. Twin contacts increase the contact reliability considerably, especially when switching low currents and voltages (dry circuits) and/or are used for reduction of contact resistance. Bifurcated contacts are twin contacts with the two contact points on one contact member (contact blade).

U_{rtd}

See > 'Rated voltage'.

Vibration resistance (destructive)

This test is used to evaluate the resistance of the relay to heavy mechanical vibration leading to a permanent damage to the relay. This test is performed according to the IEC 60068-2-27, Ea test.

Vibration resistance (functional)

This test is used to evaluate the resistance of the relay to harmonic mechanical oscillations such as those that could occur in transport or during operation. No opening of closed relay contacts or closing of open relay contacts with a duration >10 μs is allowed to occur during the test. This test is performed according to the IEC 60068-2-6, Fc test. Unless otherwise stated the values refer to a frequency range 30...150 Hz.

Voltage drop

Effect of contact resistance. See > 'Contact resistance'.

VSWR

Abbreviation for 'Voltage Standing Wave Ratio'. The ratio of the maximum to the minimum voltage set up along a transmission by reflections.

Wash tight/immersion cleanable

See 'Category of protection (IEC 61810)' - RT III.

Relays that can be cleaned together with the printed circuit board after soldering. The washing requires a suitable solvent. The term „immersion cleanable/wash tight“ is not identical with „hermetically sealed“! Unless otherwise stated the relays are wash tight according to Qc2 IEC 60068-2-17, tested with a water immersion test at max. ambient temperature for 1 minute.

Contact our technical support for suitable solvents and washing parameters. The user needs to verify the compatibility of lacquer, solvents and drying process.

Handling, Processing, Testing and Use

Electromechanical relays are one of the most robust and reliable components. To achieve the specified performance some precautions must be taken during transportation, storage, handling, processing and testing.

CAUTION: ANY TRANSPORT, PACKAGING, HANDLING OR USE DIFFERENTLY THAN HEREIN RECOMMENDED BY TYCO ELECTRONICS MAY CAUSE RISKS AND IN THIS SITUATION SHALL BE ENTIRELY BORNE BY USER.

Handling / Logistics

Transport

During transport, care has to be taken to avoid excessive shock and vibration. Mechanical stress can lead to changes in operating characteristics or to internal damage of the relay (see > 'Vibration and shock resistance'). When a potential excess of mechanical stress is suspected (e.g. damaged packaging, dropped packages or relays, etc.), the relays should be checked and tested before use.

Packaging

Depending on the relay type and design and with regard to specific requirements various packaging types and technologies are used for shipment of our products.

- THT and THR relays
are packed in trays, cardboard or plastic tubes with stoppers on both sides of the tubes. For unpacking from plastic tubes the plugs on both sides shall be removed to prevent any relays sticking to the plugs and possible falling down onto the pick place.
- SMT relays
the standard packing are blisters tapes wound on a reel (tape & reel) and dry packed in order to prevent the relays from humidity. The SMT relays should be kept in these containers for storage and should be removed from the box just only before the assembly process preferably at the SMT assembly line. The boxes are equipped with shock absorbers, which protect the relays from mechanical impacts.
- Industrial relays are packed in trays or in tubes.

Handling

Modern relays are high precision components, sensitive to mechanical stress and abusive handling. Care must be taken when handling the relay during all stages of production.

- special attention must be paid, not to apply mechanical shock, e.g. by dropping relays onto the floor or other hard surfaces (e.g. assembly tables). Once dropped, relays should not be used anymore and shall be scrapped. In case of relays assembled to long wires or harnesses any mechanical shock due to whiplash effect has to be avoided.
- care has to be taken when opening tubes to prevent relays from falling out or during splicing of reels, where the loose end of the tape should not drop to the floor.
- special care must be taken, that the terminals of the relays are not bent. Straightening of bent terminals and pins is not allowed.
- handling or processing of relays in bulk is not permitted.

Storage

Generally Tyco Electronics' products should not be exposed to extreme high temperatures, high humidity or damaging media such as sulphurous, acid or basic atmospheres. Unless other specific requirements are documented, Tyco Electronics recommends in accordance with IEC 60068-1 a standard atmospheric conditions a storage temperature between 15 and 35°C (59 to 95°F) and a relative humidity between 25 and 75 %.

Dry packed SMT relays: when the packing is opened, the relays must be soldered within a defined time frame, indicated by the moisture sensitive level MSL (max time from opening the bag to soldering). When the open time is exceeded, remaining relays shall be dry repacked, or the relays must be dried before soldering.

For more information, refer to our application notes in the internet.

Processing

Testing

For electrical incoming inspection tests refer to sections > 'Contact resistance', 'Diagnostics of relays' and 'Storage'.

During incoming inspection and respective handling, special care has to be taken not to bend the relay terminals. The degradation of sealing properties up to internal failures (e.g. breaking of coil wires) could be the consequence.

Handling during processing

Relays are high precision components, sensitive to mechanical stress and abusive handling. Care must be taken when handling the relay during all stages of production. Do not exert any pressure on the pins.

Manual handling

- the relays have to be removed from the packaging in an orderly way
- processing of relays in bulk is not permitted
- when relays are manually handled and placed on PCB's, special attention must be paid, not to drop relays onto the floor or other hard surfaces (e.g. assembly tables). Once dropped, there is a risk of high mechanical shock and potential damage of the relay; these relays should not be used anymore. In case of relays assembled to long wires or harnesses any mechanical shock due to whiplash effect has to be avoided.
- open packages, tubes or splice reels with care: after prolonged storage at higher temperature there is a risk of relays sticking to the stopper plugs of tubes and for reels the loose end of the tape shall not drop to the floor.
- special care must be taken, that the terminals of the relays are not bent. Straightening of bent terminals and pins is not allowed.
- do not exert undue force (e.g. by hand tools) when inserting the relays onto a pcb or into a socket.

Automatic handling

- the mechanical stress caused by handling and/or force of automatic feeders or robots has to be adjusted to avoid mechanical damage (e.g. cracking of the relay case, detaching cap from relay base).
- the clamping force shall not exceed the values given for x, y, z direction, in order to provide for the proper internal function of the relay. The force shall be applied in the largest possible area. Picking in the dashed area would be preferred. Unless otherwise stated the clamping force should not exceed 5 N in any of x/y/z direction.
- do not exert undue force when inserting the relays onto a pcb or into a socket.

Mounting on PCB's

- the relays have to be removed from the packaging in an orderly way, processing of relays in bulk is not permitted. Dimensions and pcb layout indicated in the datasheet are indicated for the manual placement on the pcb's. For automated pick-and-place we refer to detailed component drawings.
- unless otherwise stated the relay can be mounted in any position. The relays can be further processed in the industry standard commercial soldering and cleaning (for suitable products) plants.
- when inserting the relay into the PCB, do not exert any pressure or use undue force or torque on the pins as this may compromise the pin seal or affect the integrity of the coil connections.
- no pressure should be exerted on the relay cover and terminal pins after the relay has been inserted in the printed circuit board.
- after insertion in the printed circuit board, the terminal pins must not be bent or twisted for fixation or attachment. Bending or applying mechanical stress to the pins may affect the relay parameters. Bending the terminal pins of sealed relays (wash-tight, immersion proof, sealed) may damage the sealing. However, if fixing must be carried out before soldering, please contact our application support. Also see > 'Clinching'.

Handling, Processing, Testing and Use (Continued)

Mounting of relays and accessories on sockets and DIN-rails

When inserting the relay onto sockets, do not exert undue force on the relay and/or pins (e.g. indicated max. insertion force).

Reduced ambient temperature ranges may apply for mounting and handling of sockets and accessories (mounting on DIN-rail, assembly of retaining clips, mounting/dismounting of relays etc.); unless otherwise stated provide a temperature of -10°C to +40°C for ambient and parts for such mounting processes.

Clinching

Terminals should not be bent to hold the relay in place on the PCB to aid flow soldering. Bending or cutting the pins after insertion generates extreme mechanical stress, especially in the case of rectangular PCB terminals.

Neither the relay performance nor sealing of flux resistant and plastic or hermetically sealed relays can be guaranteed if the terminals have been bent. Also see > 'Mounting on PCB's'

Fluxing

Fluxing has to be carefully considered depending on the type of relay.

- Sealed relays, wash-tight relays: these relays may be processed on all standard commercial fluxing, solder and cleaning equipment for this type of electrical and electromechanical components.
- Unsealed relays, open relays, dust-proof relays: should be hand soldered to avoid flux contamination of the relay. Flux should be used sparingly and evenly and joints examined after soldering. If flow soldering is used however, the flux level has to be set so that it merely touches the bottom of the PCB and only wets the underside of the printed circuit board. It must not flood onto the upper surface of the PCB. This is particularly critical if multilayer PCB are used and there are unused holes under the body of the unsealed relay, the flux should only be visible as foam flux through any open perforations in the printed circuit board. If the printed circuit board is flooded by flux, bursting flux bubbles can lead to contamination in open relays and, consequently, to failures. To protect against corrosion, no acidiferous flux should be used. The recommended flux types are 1.1.3, 1.2.3 or 2.2.3 according to DIN EN 29454 T.1 or type F-SW 32 to 34 to EN 29454-1 (ISO 9454-1).

If there is any doubt about the fluxing process, sealed relays (wash-tight, plastic or hermetically sealed) should be used.

Acidic fluxes are not suitable for open relays due to the risk of corrosion, especially inside the coil.

Preheating

During preheating for common wave soldering processes, the temperature of the upper surface of the printed circuit board should not exceed 120°C. Excessive exposure to high temperatures may affect the relay characteristics. NOTE that any not completely dried flux might evaporate in an explosive reaction and sputter; ensure that no flux penetrates the insides of open relays.

Soldering

The soldering process has to be controlled carefully in order not to impair the performance of the relays. No external force to be applied on the pins during the soldering process.

Our relays can be processed in commercial soldering and washing installations (if classified as washable). They cover the following regulations:

Flux tight type relays; open relays without cover:

- Solderability according to IEC 60068-2-20, Test Ta, method 1, aging 3: 4 hours at 155°C, dewetting
- Resistance to soldering heat according to IEC 60068-2-20, test Tb, test method 1A

Sealed type open vent hole relays:

- Solderability according to IEC 60068-2-58; dewetting
- Resistance to soldering heat according to IEC 60068-2-58

Sealed type washable relays:

- Such relays are capable of being automatically soldered and subsequently undergoing a washing process to remove flux residues without allowing the ingress of flux or washing solvents
- Sealing complies to IEC 60068-2-17; Test Qc: method 2, the relay will withstand a bubble test at 70°C for 1 min
- See also > 'Chemical Cleaning'
- Avoid designs with considerable thermal mass below the relay (e.g. high number of solder filled interlayer connections).

Soldering, wave soldering

The automated soldering process has to be controlled carefully in order not to impair the performance of the relays. Flux resistant and sealed relays can be used with most dip or wave soldering processes. The solder level has to be adjusted so that it does not flood the printed circuit board surface.

The pre-soldered pins are suited for standard soldering processes with Pb-solder as well as for Pb-free solder processes.

Leadfree processing:

- for processing of relays under leadfree conditions refer to the indicated 'resistance to soldering heat', exceeding the limit may have negative impact on relay parameters. We recommend that leadfree processes should be carried out using SnAgCu-solder. The solder bath temperature for i.e. double wave soldering should be in the range of 250 to 260°C.
- the solder bath temperature should not exceed
 - 270°C for 10 s for flux-proof relay versions (RT II)
 - 260°C for 5 s for wash-tight and sealed relays (RT III and higher).
- for other bath temperatures and solder time (e.g. higher solder bath temperature with reduced dipping time) contact our technical support.

SnPb processing

- for this process refer to maximum permissible temperatures at the terminals according to CECC 00802. For SnPb Eutectic Process we recommend a maximum peak temperature $T_p < 225^\circ\text{C}$. For Pb-free processing we recommend a maximum temperature $T_p < 245^\circ\text{C}$. These soldering temperature profiles indicate the Pad/Pin temperature.

Please note that in some cases the ambient temperature may be considerably higher on top area of the relay component. In this case the component temperature should not exceed 260°C. Check for specific mounting conditions. In addition to the time, parameter t_d (time span for temperature above preheating temperature) should be below 150 s.

Soldering, reflow soldering

Unless otherwise stated the soldering should be carried out according to the recommendation of IEC 60068-2-58 and according to the recommendations of CECC 00802.

In general, electromechanical relays should be soldered at the lower process limits of a soldering process.

Soldering, manual soldering

The relay programme offers products with various terminal styles. Some products with solder lugs are specifically designed for manual soldering whereas some products (e.g. with quick connect terminals) are not intended to be soldered. Most PCB mount relays are designed for processing in a wave soldering process. For manual soldering and repair the soldering time should be kept to a minimum and no mechanical force or torque must be applied to the relay terminals.

Unless otherwise stated we recommend for manual soldering a soldering temperature of 300 to 350°C for a maximum soldering time of 3 s.

Cooling

After wave or reflow soldering, the assemblies should be cooled in order to reduce thermal stress and to minimize the pressure difference between inside of the relay and ambient. Do not change the temperature suddenly, especially avoid thermal shock for the hot relay. Do not cool down by using cold liquids or aerosols. In case of thermal shock, the relay sealing could break and through micro-cracks cleaning fluid with dissolved flux might be sucked inside the relay; such ingress of liquids into the relay can lead to failures in operation.

Handling, Processing, Testing and Use (Continued)

Cleaning, chemical

Preferably a non clean flux process should be used; in this case there is no need to wash the PCB and we recommend avoiding washing processes in order to protect the environment. If cleaning is necessary, certain precautions have to be taken:

Flux tight type relays and sealed relays with open vent hole:

- immersion cleaning is not possible with these types of relays. Only the soldered side of the PCB (THT) should be cleaned and care has to be taken not to allow washing solution to flood the PCB surface to prevent penetration of solvent and dissolved flux into the relay. Any other cleaning method involving potential contamination of unsealed relays must be avoided.

Sealed relays (wash-tight, sealed and hermetically sealed), closed vent-hole:

- do not stress the terminals mechanically before or during the mounting, soldering or cleaning process
- the printed circuit must be washed immediately after the soldering process
- the PCB should be allowed to cool prior to the washing process to avoid thermal shock and potential damage to the seal as well as a pressure difference (see > 'Cooling')
- do not lower the temperature while the relay is in contact with any liquid, e.g. some residue of cleaning medium can be between relay and PCB
- modern cleaning equipment uses water or alkaline solutions, if other cleaning solvents are used, ensure that the chemicals are suitable for the relay. The use of unsuitable solvents can cause cracking or discoloring of the plastic parts. Suitable solvents include isopropyl alcohol (alcohol-based solvents), water with wetting agents. Unsuitable solvents are, e.g., acetone, ethyl acetate, aqueous alkalines, phenolic combinations, thinner-based solvents, chlorosenebased solvents, trichlene-based solvents and chlorine.
- when using high pressure cleaning processes, special care has to be taken to avoid any ingress into the relay as liquids under high pressure can damage the seal of the relay. Do not use jet pressure higher than 1,5 bar or ultrasonic pressure higher than 0,5 bar.
- avoid and do not use any ultrasonic pressure for relays with gold plated contacts. See > 'Ultrasonic cleaning'
- special care must be taken on the temperature of the cleaning and rinsing liquid; their temperature shall be similar and not deviate by more than 10°C.
- the individual wash stations must be separate from one another to prevent cross-contamination!
- after the final washing process, the printed circuit boards must be cleaned again using a clean washing medium!

Cleaning, ultrasonic

Ultrasonic cleaning is generally not recommended as this can cause friction welding of the contacts, especially in the case of gold-plated contacts. If ultrasonic cleaning cannot be avoided, it must be completed as quickly as possible.

For gold plated contacts ultrasonic cleaning is NOT recommended as this might result in cold welding of the gold contacts.

Protective coating

Relays with a category of protection II and below are not suited for coating processes. Relays with category of protection III and higher are suitable for washing processes but not all relays are necessarily suited for coating processes. In this case, please contact our application support for recommended relay versions and processes.

In case relays with insufficient protection are coated, there is a high risk that resin will enter the relay and destroy the relay. Sealed relays with an opened vent hole can only be partly coated.

- for the protective lacquering and varnishing of the mounted printed circuit boards, we recommend single-component lacquer (epoxy-based). Suitable are Epoxy, Urethane and Fluorine coatings. Silicon containing lacquer or potting compound must not be used!
- we recommend a coating technology that avoids uncured varnish in the surrounding of the relay.
- the maximum drying temperature should be 70°C.
- the user has to conduct thorough testing with their processes, used lacquers, coatings or casting compound. Solvents may damage the component case or compromise their sealing properties.
- do not allow de-varnishing of PCB for repair, if unavoidable the relay has to be replaced.

NOTE:

- Lacquer or potting compound containing silicon MUST NOT be used!
- Coatings, especially potting compounds may impact the heat dissipation of the relay. Therefore it is necessary to conduct thermal tests of relays in potted assemblies.

Vent hole, nip-off pin, opening

Most PCB relays, reflow solderable relays as well as THR and SMD relays, are provided with a closed vent hole on top of the cover (removable sealing pin on relay cover).

Inside a sealed relay certain load conditions (e.g. heavy loads with generation of pronounced arcing) and/or extreme ambient conditions can generate aggressive atmosphere (diffusion, arc ionization), corrosive condensate or overpressure. To avoid such conditions and a possible reduction of electrical endurance a gas exchange with the atmosphere is advised. To allow the gas exchange, break off the vent hole or nip-off pin.

Silicone

Materials containing silicone or its derivatives must not be used in any form in or near to processing and packaging of subcomponents and the final relay assembly. Silicone and its derivatives are not allowed in the material of any component in the vicinity of the relays.

Silicone atmosphere can diffuse through the relay housing and cause contact failures, siliceous compound deposits can create an insulating abrasive layer on the contact surface.

Contamination can occur with all silicone-based materials before and after cure (contain silicone volatiles), silicone aerosols, silicone fluids, grease and hand cream, etc..

Some types of signal relays are suited for application in Silicone environment, however the suitability MUST be verified; please contact our application support.

Testing

Testing

During incoming inspection, special care has to be taken not put mechanical stress on the relays and terminals and not to bend the relay terminals; internal failure or long term effects as a result of a degradation of sealing properties could be the consequence.

Bistable relay, incoming and in-process testing

In a bistable or latching relay the contacts maintain the last switching position when the coil input voltage is disconnected.

NOTE that even though the bistable relays are leaving production preferably in reset contact position, the position of the contact (set position/ reset position) is not defined at delivery or after transport. Thus, at the time of incoming and in-line testing, the customer needs to check the contact position and to set/reset the relay to the required position.

Handling, Processing, Testing and Use (Continued)

Testing conditions, automated testing/diagnose

With higher integration and use of highly complex electronic circuits and resulting quality and safety requirements (e.g. cars), relays undergo stringent incoming tests and in-circuit testing during and at the end of the assembly process (end-of-line tests).

Special considerations have to be given for the selection of testing parameters, the respective test limits and development of embedded diagnostic routines:

- testing of contact resistance
- testing of magnetic system
- testing of dynamic characteristics.

The most common contact materials contain silver alloys and thus are affected by sulfidation and oxidation. Layers of oxides, sulfides and other compounds will form on the surface of metal contacts within a very short time by absorption from the ambient atmosphere. These layers increase the contact resistance, depending on the thickness of the layer, the effective contact area and the specific resistance of the used contact material and layer. To establish a reliable electric contact these layers have to be destroyed. This can be done by mechanical, electrical or thermal destruction:

- mechanical destruction: high contact pressure and mechanical switching impact
- electrical destruction: requires a specific breakdown voltage and current. This destruction process is called A-fritting. The breakdown voltage depends on the thickness and specific resistance of the layer. For practical testing refer to the values according IEC 61810-7 as indicated above; e.g. for automotive relays the breakdown voltage can be up to 3 V to start the A-fritting.
- thermal destruction: a thermal destruction requires high temperatures, usually generated by
 - 1) after the electrical breakdown (A-fritting) a small current is forced through very thin channels in the layer. The resulting local high current density heats the conducting channels up quickly, destroying the layers, until finally (within a few ms) a metal to metal bridge is established. This process is called B-fritting. The B-fritting voltage depends on the contact material. For practical testing refer to the values according IEC 61810-7 as indicated above.
 - 2) generated by high contact currents and/or electric arcs (e.g. disconnecting inductive loads, switching on capacitive loads).

Icing

Under very special environmental conditions (below 0°C) and operational, temporary relay switching failures can occur. Moisture condenses on the surface of the cold contact and forms a thin layer of ice, causing a temporary interruption of the electrical contact.

Magnetic system, coil resistance

For testing the inductivity of relay coils may need consideration (e.g. the inductivity for coils in automotive relays can exceed 1 H in the unsaturated range). This results in a time constants between 1 to 50 ms for the exponential inductive current increase (pulse response). In case the ohmic coil resistance is measured with a 4-pole measurement, the resistance value may be wrong, if measured during the inductive current rise after energization.

Dynamic characteristics

The switching times (e.g. operate time and release time) for DC-coils are usually in the low millisecond-range:

- the operate time depends on the applied coil voltage and coil temperature. Voltages higher than the rated coil voltage generally leading to reduced operate times whereas higher coil temperature and the resulting higher coil resistance leading to increased operate times. A fast dynamic response (e.g short operate and release time) also impacts the bounce time and can increase the bounce time considerably.
- the release time depends mainly on whether a coil suppression circuit is used and on the type of the used circuit. A low ohmic device (e.g. a diode) in parallel to the relay coil can increase the release time by a considerable factor compared to the typical values shown in the datasheets.

Diagnostics of relays, recommendations

For the development of diagnostic routines these effects need to be considered:

- the contact resistance may be higher than indicated in the datasheet and due to the fritting phenomena (see above > 'testing'), also may show a non-linear characteristic. This implies, that the contact resistance, measured at too low voltage and current levels (e.g. standard tester and multimeter) can be significantly higher than the contact resistance under real application conditions (e.g. supplying a 100 W load). We recommend to perform the diagnostic routine with the actual application load and voltage (e.g. mains or board net voltage) connected to the contacts. If the diagnostic routine cannot be performed with actual application load and voltage, the measurement voltage level must secure an electrical breakdown of possible layers. We recommend a voltage level according to IEC 61810-7.
- the voltage drop can be 300 mV. The B-fritting is a physical phenomenon, which can occur on all metal and silver based contacts. For low level and signal applications, special signal and general purpose relays are available. For automotive applications it is recommended to set the diagnostic threshold voltage to 500 mV per relay contact (important for H-bridges or serial contact arrangements).
- effects like icing (see > 'Icing').
- consider the maximum possible switching times (due to, e.g., operate voltages other than the rated coil voltage, bounce time effects, ambient temperature and coil suppression circuits). If the status of the contact has to be changed for the diagnostic routine (energize or de-energize relay), the routine must wait until the intended contact status is established. Depending on electrical and ambient conditions (temperature, voltage levels, coil circuits) the times can be significantly longer than the indicated times in the datasheet. We recommend a delay time of min. 10 times of the typical switching times.
- a coil diagnostic routine must secure that the status of the contact does not change during the diagnostic cycle. If the coil driver is monitored by a watchdog routine, the energizing/de-energizing time of the coil must not result in an unintended closing or opening of the contacts. We recommend times of max. 0.5 ms.

Use

Operational humidity / Condensation

Standard conditions:

Annual mean relative air humidity ≤ 75% at ambient temperature 23°C, on 30 complete days distributed naturally over the year 95% at ambient temperature ≤ 25°C, on the remaining days occasionally 85% at 23°C. No condensing or freezing allowed (storage and/or use).

For use and storage at other conditions, condensation or freezing due to temperature changes has to be avoided. Use and storage within the limits indicated in the graph.

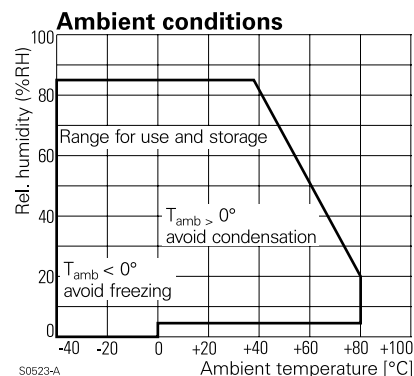

Description Explanation

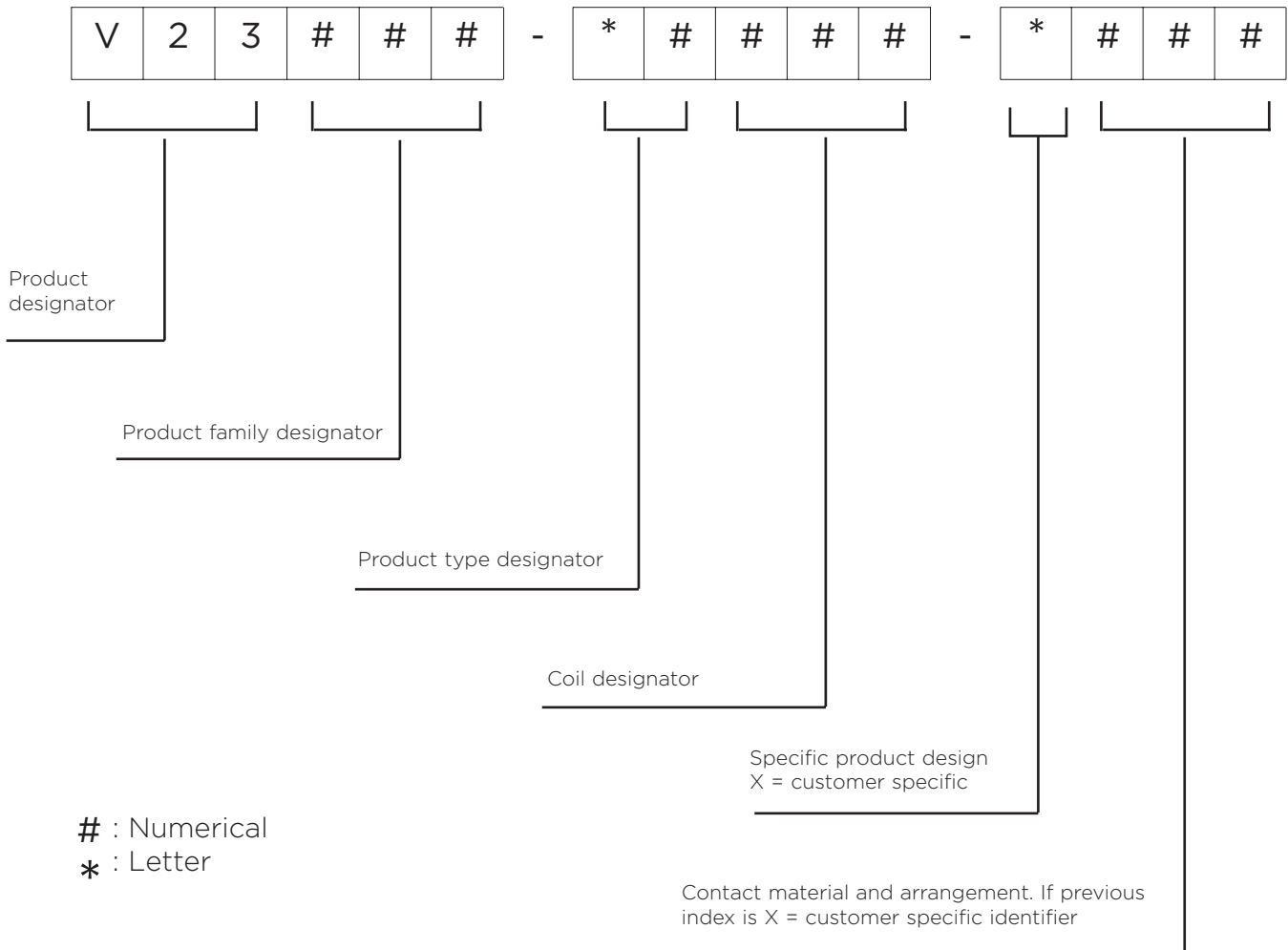

Example

Relay Description	V23072-A1061-A303	V23086-C1021-A502
Relay Family	Mini Relay K	Micro Relay K
Relay Type	Open version	Sealed version
Coil Designator	12 V	12 V
Design	Standard version	Standard version
Contact Material and Arrangement	AgNi0.15, CO	AgSnO ₂ , NO

Determining Relay Coil Inductance

Relay users often desire to know the inductance of the relay coil they are using so they can determine the energy released by the coil upon deenergization.

Coil inductance with armature seated is greater than that when unseated. This is because inductance varies directly with incremental permeability (μ) and inversely with the length (ℓ) of the magnetic circuit path. The air gap in the magnetic circuit of an unseated armature both decreases μ and increases ℓ . Of course, the greater the inductance, the greater the energy released into the coil circuit upon deenergization.

Inductance also will vary with coil voltage, since permeability varies with magnetizing force which, in turn, is determined by coil voltage. For values most meaningful to the circuit designer, inductance should be measured under conditions that simulate actual relay service; that is, at rated voltage and current.

Inductance with armature seated represents actual application conditions at the instant coil power is removed. When coil power is removed, the coil generates a counter voltage, $-e = L(di/dt)$, which is fed back into the switch circuit. Depending on energy levels, this voltage surge may adversely affect the life or operational characteristics of the switch that controls the relay coil. (For methods to protect the switch, see "Coil Suppression Can Reduce Relay Life", 13C3264.)

The inductance of DC coils should be measured by the $L = tR$ method by use of an oscilloscope. This method requires the application of rated DC voltage to the coil while physically holding the armature seated. The value, t , is the time for coil current to increase to .623 of its steady state value, and R is the coil DC resistance in ohms as measured by an ohmmeter.

The inductance of AC coils may be determined by measuring coil voltage and current and actual power consumed by use of a wattmeter. The product of coil voltage and current is the "VA" in the following equation, "W" is the power as given by the wattmeter. R = measured DC resistance in ohms.

$$L = \frac{X_L}{2\pi f} = \frac{Z \sin \theta}{2\pi f} = \frac{(R/\cos \theta) \sin \theta}{2\pi f};$$

$$\text{where } \theta = \cos^{-1} (W/VA).$$

If a wattmeter isn't available, inductance may be determined by use of a dual-trace oscilloscope, one input of which is fed by a current probe. In this method, rated voltage at the proper frequency is impressed on the coil, and the time displacement, t , of applied voltage and coil current is measured by the oscilloscope. Inductance is calculated as above, where:

$$\theta = \frac{360^\circ t}{16.7 \text{ ms}}$$

t = time in ms by which coil current lags coil voltage.

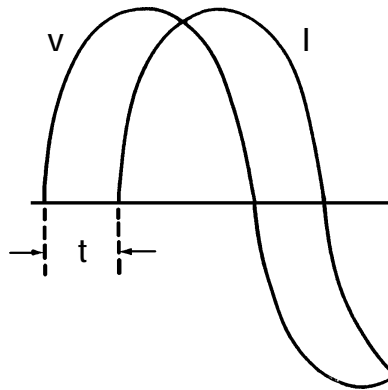

Diagnostics of Relays

Introduction

With the increase of electronic circuits and safety requirements in cars, more and more switching contacts are monitored by diagnostic routines. Similar routines are used by the system suppliers before, during and after the assembly processes (In-Circuit and End-Of-Line tests) as well.

Automotive relays are originally designed to switch real automotive applications (e.g. motors, lights, heating, etc.) with a load voltage of 12VDC (or 24VDC or 42VDC) and load currents above 1A. Lower diagnostic current and voltage levels can result in wrong interpretations of the state of the relay contact.

This paper explains the technical background of the relay contact system, coil system and dynamic behavior and gives recommendations for applicable diagnostic routines.

Contact System

The most common contact materials for automotive relays are fine grain silver ($AgNi_{0.15}$) and silver tin oxide ($AgSnO_2$). Both materials are affected by sulfidation and oxidation. These layers of oxides, sulfides and other compounds will be formed on the surface of metal-contacts by absorption of gas molecules from the ambient atmosphere within a very short time. The layers will increase the contact resistance. The resistance of such layers depends on the thickness of the layer, effective contact area and the specific resistance of the contact material/layer. To get a reliable electric contact these layers have to be destroyed. This can be done by mechanical, electrical or thermal destruction. A mechanical destruction requires high contact forces. With the very high degree of miniaturization of automotive relays, those contact forces cannot be safely achieved, especially for normally-closed contacts. An electrical destruction requires a specific breakdown voltage and current. This destruction process is called A-fritting.

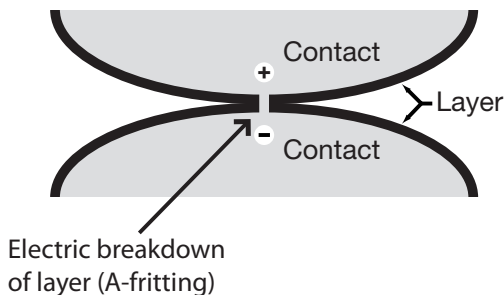

Fig. 1 Contact layers

The breakdown voltage depends on the thickness and specific resistance of the layer and can reach theoretically some hundred volts. In the practice of automotive relays the breakdown voltage can be up to 3VDC. A current of min. 10mA is needed to start the A-fritting. After the electrical breakdown a small current is forced through very thin channels in the layer. The resulting local high current density heats the conducting channels up quickly, destroying the layers, until finally (within a few ms) a metal to metal bridge is established. This process is called B-fritting. The B-fritting voltage depends again on the thickness and specific resistance of the layer and can reach in the practice of automotive relays up to 300mV.

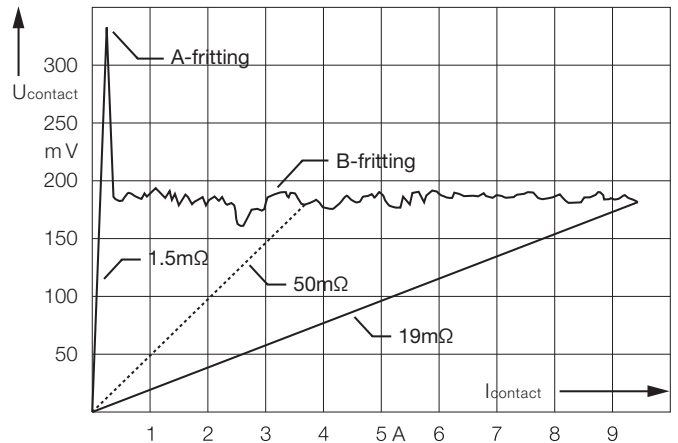

Fig. 2 Fritting of a relay contact

A thermal destruction requires high temperatures, which will only be generated by high contact currents or electric arcs (disconnecting inductive loads). The thermal destruction can only take place, after an electrical destruction.

Coil System and Dynamic Behavior

Automotive relay coils are designed for DC-voltages. The switching times (i.e. operate time or switch-on time and release time or switch-off time) are usually in the low millisecond-range. The operate time depends on the applied coil voltage. Fig. 3 shows the relation of the operate time and coil voltage, related to the actual pull-in voltage. The nominal voltage in the displayed case is 170% of the actual pull-in voltage at an ambient temperature of 23°C (e.g. 7VDC pull-in voltage at 12VDC nominal voltage). Higher coil temperatures increase the pull-in voltage and subsequently increase the operate time at the same applied coil voltage. Including possible contact bouncing, the operate time can be three times as high as the typical values shown in the datasheets.

Diagnostics of Relays

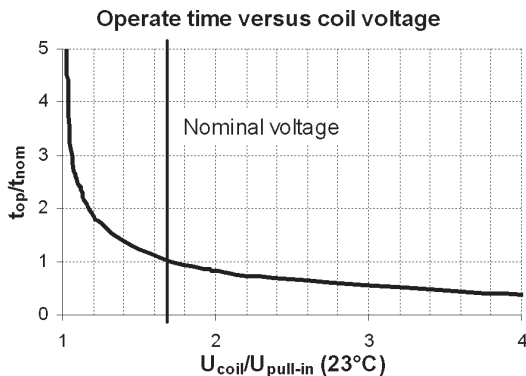

Fig. 3 Operate time

The release time depends mainly only on the used coil suppression. A low ohmic device (e.g. a diode) in parallel to the relay coil can increase the release time by a factor of up to 4 compared to the typical values shown in the datasheets.

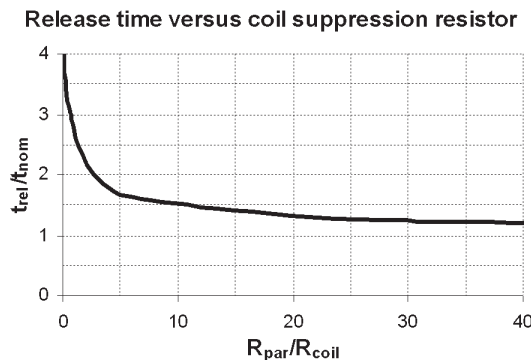

Fig. 4 Release time

Coil Resistance

The inductivity of automotive relay coils can exceed (in the unsaturated range) 1H. This results in time constants tau between 1 to 50ms for the exponential inductive current increase (jump response). If the ohmic coil resistance is measured with a 4-pole measurement, the resistance value will be wrong, if it is measured during the inductive current increase after switch on.

Remarks

1. During the lifetime of the car, the relay parameters can alter due to ageing processes like contact erosion, fretting corrosion and relaxation. Moreover the environmental requirements (temperature, vibration etc.) in the car are higher than in IC- or EOL-tests. Therefore we recommend for diagnostic routines in the car a higher threshold voltage (approx. 3VDC) and higher delay times (min. 15 times of the typical switching times).
2. Most of the applications, switched by relays, are not safety related. If a potential relay failure is detected, we recommend to not block any further activation of the relay but to write the occurrence into the error memory.

Recommendations for Diagnostic Routines

A contact diagnostic routine must:

Take into account, that the contact resistance may be non-linear. Due to the explained fretting phenomena, the contact resistance can be non-linear. This means, that the contact resistance, measured at low voltage and current levels (e.g. standard multimeter) can be significantly higher than the contact resistance under real conditions (e.g. supplying a 100W load). We recommend to perform the diagnostic routine with the real application and real board net voltage connected.

Supply a sufficient voltage and current to force the A-fritting. If the diagnostic routine cannot be performed with real application and voltage, the measurement voltage level must secure an electrical breakdown of possible layers. We recommend a voltage level of min. 5VDC and current of min. 100mA for min. 1ms.

Accept, that the voltage drop can be 300mV. The B-fritting is a physical phenomenon, which can occur on all silver based contacts. For signal-applications, special signal relays are available. We recommend to set the diagnostic threshold voltage to 500mV per relay contact (important for H-bridges or serial contact arrangements).

Regard the maximum possible switching times. If the status of the contact has to be changed for the diagnostic routine (energize or de-energize relay), the routine must wait until the intended contact status is reached. Depending on ambient conditions (temperature, voltage levels, coil circuits) the times can be significantly longer than the specified typical times. We recommend a delay time of min. 10 times of the typical switching times or min. 20ms after first contact status change at min. 110% pull-in voltage.

A coil diagnostic routine must:

Secure, that the status of the contact does not change during the diagnostic. If the coil driver is monitored by a watchdog routine, the energizing/de-energizing time of the coil must not result in an unintended closing or opening of the contacts. We recommend times of max. 0.5ms.

Electromechanical vs. Solid State Relay Characteristics Comparison

	Characteristics	EMR	SSR
General	Sensitivity to withstand misuse or misapplication	Good	Poor
	Sensitive to corrosion, oxidation, or contaminates	Yes	No
	Sensitive to shock, vibration or acceleration	Yes	No
	Sensitivity to radiation	Fair	Poor
	Package versatility	Good	Fair
	Cost per pole	Best	Fair
	Input TTL & CMOS (buffer) compatibility	Fair	Best
	Operate and release time	5-20 mS	.25-10 mS
	Compatibility of military/aerospace specs.	Good	Poor
	Ease of troubleshooting	Good	Poor
	Input to output isolation capability	4Kv	>4Kv
	Normal failure mode (output)	Open	Shorted
	Normal wearout mechanism	Contacts	LED
*Output Switching Capabilities	Physical size per pole	Best	Fair
	Available output contact forms	1A, 1B, 1C	1A, 1C, 2A, 4A
	Multipole capability from single input	Yes	Some
	Electrical life expectancy (operations)	>100K	>100 Million
	Capable of rapid duty cycle switching	Some	All
	Capable of AC & DC voltage switching	Yes	Some
	Capable of inductive load switching	Yes	Yes
	Capable of resistive load switching	Yes	Yes
	Capable of capacitive load switching	Yes	Yes
	Capable of low level load switching	Yes	Some
	Capable of dry circuit load switching	Yes	No
	Capable of coaxial load (RF) switching	Yes	No
	Capable of precision synchronous switching	No	Yes
	Capable of zero voltage turn-on/zero current turn-off	No	Yes
	Output contact off-state resistance	>1 M ohms	>20K ohms
	Output contact on-state resistance	<.05 ohms	<.1 ohms
	Output contact arcing	Yes	No
	Output contact bounce	Yes	No
	Level of EMI/RFI generated (emitted)	Large	Small
	Derating of output current required above $T_A=25^\circ\text{C}$	No	Yes
	Heatsink required to switch maximum rated loads	No	Some
	Inrush surge current capability (ref. to max. rated current)	1-5 times	2-10 times
	On-state surge current capability (ref. to max. rated current)	1-5 times	2-10 times
	Sensitive to explosive environment	Yes	No
	Sensitivity to magnetic fields	Fair	Good
	Sensitive (susceptibility) to EMI/RFI false operation	No	Yes
	Sensitive to ESD (electrostatic discharge) turn-on	No	Yes
	Sensitive to overvoltage turn-on	No	Yes
Sensitive to thermal turn-on	No	Yes	
Sensitive to dv/dt turn-on	No	Yes	
Sensitive to load di/dt turn-on	No	Yes	

*Ability is highly application dependent

Glossary

Technical relay terms are used differently. Depending on the relay application and the relay supplier you will face a variety of terms. For this catalog, we preferred technical terms according to IEC/EN 60 255 Part 1-00.

A

Ambient temperature

Temperature in the direct environment of the relay. Potting can hamper heat transport and consequently lead to a derating of the relay parameters (e.g. continuous current and switching capability).

Arc

Plasma current flow between opening relay contacts. An arc is enabled by the electric power of the load circuit (turn off spark) ionizing the gas between the contacts. The stability of the arc depends on various parameters such as → contact material, air pressure, → contact gap, etc. An arc locally produces high temperature causing contact erosion. In cases of strong erosion, → spark suppression becomes necessary.

Caution

If a relay that is not especially designed for 42 V applications has to switch off a 42 V load, depending on the conditions (→ contact gap, → load limit curve) an arc of infinite duration could occur. Due to the high power consumption in the arc the relay will be destroyed.

B

Bistable relay

Same as → latching relay.

Bounce time

The time from the first to the last closing or opening of a relay contact.

Break contact, Form B

→ NC contact. The break contact is closed in the → release (rest) state of a → monostable relay and opens (breaks) when the armature moves to the core (→ operate state). See also table 1.

C

Capacitive load

Switching on a capacitive load results in high inrush current. Lamp loads show similar behavior.

Changeover contact, Form C

Contact configuration with → make and → break contact. Changing the switch position opens the closed contact first and then closes the formerly open contact. See also table 1.

Coil resistance

Electrical resistance of the energized coil not including a parallel device for → coil suppression.

Coil suppression circuit

Circuit to reduce the inductive switch off voltage peak of the relay coil (EMC protection, → switch off voltage peak). Note that most of the circuits reduce the armature release speed, which can decrease the relay lifetime, especially valid for diodes in parallel to the coil. From the various solutions, the use of a Zener diode is particularly suitable (see fig. 1). Further information is available on request.

Class of protection

Ratings for example defined in IEC 529, indicating how completely a cover, seal, etc. protects against water, humidity, dust, direct contact etc. See also protection class.

Coating

Protection of → PCB and electrical components by applying lacquers on the surfaces. For further details please see item 7 in the “Processing Information”.

Contact

Made out of → contact material and part of the → contact set where the electrical load circuit is opened or closed.

Contact carrier

Conductive metal part of the relay where the → contact is applied to.

Contact configuration, Form A, B, C

Configuration of the relay switch (→ make, → break or → changeover contact). According to the application, various contact configurations are used (see table 1). Contacts which are moved by the armature system are called → movable contacts, and non moving contacts → stationary contacts.

Contact erosion

Material loss at the contact surfaces, for example due to material evaporation by an → arc.

Contact force

Force between closed contact surfaces.

Contact gap





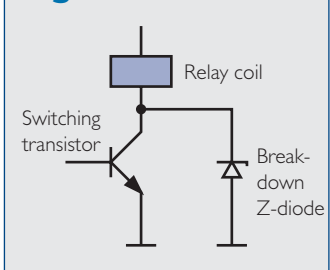

Gap between the contact surfaces of an open contact pair.

Fig. 1



Glossary

Most Common Contact Configurations

Denominations	Form	Abbreviations/Symbols NARM Abbreviation	Symbol of Circuit Element
Make contact Double contact make (bifurcated)	1 Form A 1 Form A (Double contact make)	SPST-NO SPST-NO DM	
Break contact	1 Form B	SPST-NC	
Make and break or Changeover contact	1 Form C	SPDT	
Double make contact on armature	1 Form U	SPST-NO DM	
Double break contact	1 Form V	SPST-NC DB	
Double make contact	1 Form X	SPST-NO DM	
Triple make contact	Form 3	-	

¹⁾ 1 Form A
²⁾ 1 Form A (Double contact make)

Table 1

Contact material

For relays a variety of contact materials are in use. They operate under a wide range of loads in terms of voltage and current. Inductive loads can cause high switch off voltages and strong → arcs, capacitors create inrush current peaks. Arcs and improper → coil suppression can reduce the lifetime of a contact. So far, no universal contact material is known, that can be used on all load types with optimum performance. Contact manufacturers, relay developers, and users have established the following criteria to describe a contact:

- Electrical resistance
- Resistance to contact erosion
- Resistance to material transfer
- Resistance to welding

These criteria can be used to classify the most important contact materials according to their performance as shown in table 2 on the next page.

The table lists the major contact materials for automotive use. As the load rating for a contact depends on the used relay design as well (contact force etc.), the specification of one relay type cannot simply be transferred to others.

Contact/relay resistance (voltage drop)

Electrical resistance between the relay load terminals while the respective contact is closed. The resistance can be obtained out of the ratio of the voltage drop across the relay and the load current (Ohm's law). Surface layers (→ fritting) can result in non-linear contact - resistances and increased voltage drops (see chapter Diagnostics of Relays).

Contact set

All contacts in a relay.

Glossary

Contact Materials

Switching function current range	Load type inside vehicle	Best-suited contact material
Switching and carrying currents 0.5 A < I < 10 A at 12 V	In low power applications	AgNi0.15 or AgSnO ₂
Periodical switching and approx. 10 ⁶ operations 1 A < I < 10 A at ≥ 12 V	Long-life indicator switches	AgSnO ₂
Switching and carrying of I > 10 A capacitive load	Lamps, Capacitors	AgSnO ₂
Switching and carrying of I > 10 A resistive and inductive load	Motors, Valves	AgNi0.15 or AgSnO ₂
Switching high inrush of I > 100 A	Lamp (e.g. H4), Spark plugs, Short circuit	AgSnO ₂ in special cases: AgNi2O or Tungsten pre-contact

Table 2

Cycle time

Sum of make and break (i. e.: on and off) time of a contact pair (fig. 2).

D

Double break contact, Form V

Two break contact configuration, with two electrically connected → movable contacts which operate simultaneously. See also table 1.

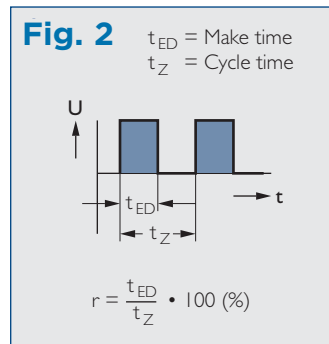

Double contact

Double contact configuration, where two → movable contacts are connected in series and operate simultaneously. In a bridge configuration, the load current flows from one → stationary contact via the bridge to a second stationary contact. See also table 1.

Double contact make or bifurcated contact, Form A (Double contact make)

Contact type with two contact studs per contact spring. Both contacts work in parallel. This is used for redundancy and/or reduction of contact resistance. See also table 1.

Double make contact, Form U

Two make contact configuration, with two electrically connected → movable contacts which operate simultaneously. As special version → main contact with pre-contact. See also table 1.

Double make contact, Form X

Two make contact configuration with two electrically connected movable contacts operating simultaneously. There is no external connection to the armature.

Drop test

Relays are dropped from a specified height onto a solid ground. This simulates the resistance to bad handling e.g. fall from a table. However we recommend to scrap dropped relays.

Dry switching

The relay contact switches no or a very small electrical load (< 1 mA, < 100 mV). See also chapter Diagnostics of Relays.

Dustproof

Covered but non sealed relay, featuring protection class IP54 according to IEC 529 → protection class.

Duty cycle

The ratio between the switch on time and total cycle time during periodical switching (see fig. 2). 50% duty cycle means the switch on time is equal to the switch off time.

E

Electrical endurance

Number of load switching operations a relay can perform without failure. The lifetime varies with the load. If not stated otherwise, the reference values shown in this data book apply for resistive or inductive loads with suitable spark suppression.

ELV

Abbreviation for End-of-Life Vehicles.

Environmental endurance

Generic term for the relay endurance under different climatic conditions. Appropriate test conditions are classified in IEC 68.

Energization, energizing value

A current driven through the relay coil to generate a magnetic field to move the armature. The energizing value is the product of the coil current and the number of wire turns of the coil.

Glossary

F

Faston blade

Flat male terminal of a plug-in relay.

Faston blade identification numbers for ISO relays

Coil and load faston blades of an ISO relay can be numbered according to two different standards. However, the terminals have the same location and function. The respective numbers are:

- 1 or 86 for the first coil pin;
- 2 or 85 for the second coil pin;
- 3 or 30 for the common load pin;
- 4 or 87a for the NC load pin;
- 5 or 87 for the NO load pin.

Fritting

See → Icing.

Fritting

Electrical breakdown which can occur under special conditions (voltage, current) whenever thin contact films prevent electrical conductivity between closed contacts. Fritting is a process which generates (A-fritting) and/or widens (B-fritting) a conducting current path through such a semi-conducting film on a contact surface. During A-fritting, electrons are injected into the undamaged film. The electron current alters the condition of the film producing a “conductive channel”. During the following B-fritting, the current widens the channel increasing the conductivity (R. Holm, Electric Contacts, 4th edition, 1967, Springer-Verlag, Berlin/Heidelberg/New York). Please also refer to chapter Diagnostics of Relays.

H

H-bridge

The H-bridge or motor-reverse circuit is used to operate a motor in two directions (e.g. door lock, steering lock, power window, seat adjustment. See chapter Automotive Applications.

I

Icing

Under very special environmental conditions and temperatures below 0°C temporary relay switching failures can occur (also defined in the Standard DIN 25424 as “secondary fail”). Moisture condenses on the surface of the cold contact and forms a thin layer of ice, causing a temporary interruption of the electrical contact.

Immersion cleanable/sealed relays

Relays which are sealed against the penetration of specified → PCB cleaners or lacquers → protection class and refer to chapter Processing Information.

Inductive load

Life expectancy strongly depends on the inductance of the load circuit.

Industrial atmosphere

Atmosphere carrying dust and certain industrial exhaust gases (sulfur, chlorine and nitrogen compounds at certain humidity levels).

J

Jump start

Short relay use at higher system voltages (like car start after flat battery).

L

Latching relay

In a latching relay, after the coil input voltage is disconnected, the contacts remain in the last reached switching position. Tyco Electronics delivers latching relays in reset contact position. However in order to eliminate influences due to e.g. transport and processing the customer is advised to check the set/reset contact position and, if necessary, to set/reset the relay into the required position. Latching relays only require a short set respectively reset impulse. A permanent coil power supply after setting/resetting the relay is neither necessary nor allowed: maximal pulse durations depend on the relay family, for details please refer to the respective datasheets. Hence the distinguishing characteristic of monostable relays in respect to a fail safe behavior is the fact that the predefined contact rest position will be reached at break down of the power supply. This behavior cannot be shown by latching relays due to the bistable working principle they are based on. Therefore latching relays should not be used in applications that are rated according to ISO/TS 16949 7.5.3 Product Identification and Traceability.

Leadfree

See chapter Processing Information.

Limiting continuous current

The highest current (effective value for AC loads) a relay can carry under specified conditions without exceeding its specified upper limit temperature. Please note that this is not the current that can be switched with any load over the specified lifetime.

Load dump

Short relay use at overvoltage (disconnection of the battery during running engine).

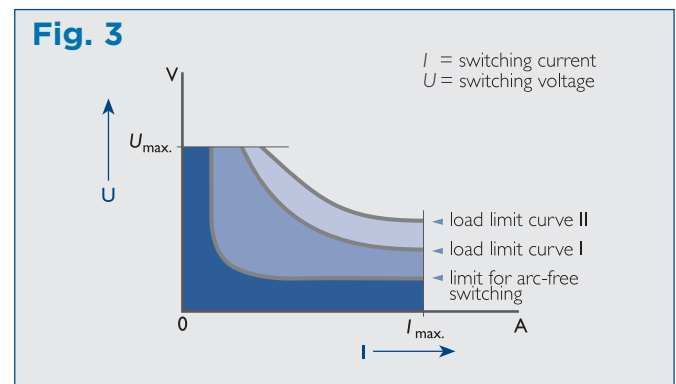

Glossary

Load limit curves

Switching limit for DC voltage and resistive loads (see fig. 3). The load limit curves were measured with low-inductive resistors, verified for 1000 switching events. The load limit curves depend on the relay design (contact gap, contact material, armature release speed, etc.). → Contact erosion and relay lifetime vary with different voltage/current values.

Load limit curve (I)

The switch off arc of all NO loads below this load limit curve extinguishes during the → transit time of the moving contact. This limit is important for → change over relays, when the → stationary NC and NO contacts are at different voltage levels, e. g. in a motor reverse application. For currents up to 100 A the load limit curve has a falling characteristic i. e. for higher currents the voltage drop across the contacts becomes lower. If a relay that is not especially designed for 24 V or 42 V loads, depending on the conditions, (→ contact gap) an arc of infinite duration could occur. In a motor reverse circuit the arc will then shortcut the battery. The current will only be determined by the resistance of the arc and could rise to several hundreds of Amps. Due to the high power consumption in the arc the relay will be destroyed.

Load limit curve (II)

The switch off arc of the NO loads below this curve extinguishes within 10 ms (the relay is already in → release position).

Load limit curve for arc-free switching

Load voltage/current combinations below this load limit curve in general cause no arc at all.

M

Make contact, Form A

→ NO contact. Contact is open in the → release (rest) state of a → monostable relay and closes (makes) when the relay coil is energized (→ operate state). See also table 1.

Main contact with pre-contact, Form U

Double make (Form U) contact with two decoupled points of contact on the movable springs. The forward contact highly resistant to burn-up, e.g. tungsten, switches the current. The main contact highly conductive, e.g. fine grain silver, conducts the current. The forward contact makes before the main contact does and opens at last.

Maximum continuous thermal load at 23°C

Maximum coil power consumption of a relay at continuous load operation at room temperature where the relay does not exceed the specified upper limit temperature.

Maximum operate voltage (or must operate voltage)

Voltage at → room ambient temperature (RT) a relay must → operate at. To guarantee proper function of all relays, the applied coil voltage in the car must be above this specified operating voltage. Please note that the actual operate voltage of an individual relay, the maximum operate voltage and the car system value are sometimes all called operate voltage.

Maximum voltage U_{\max} or V_{\max}

Maximum coil voltage at → RT, at which the coil reaches the specified → upper limit temperature without contact load (→ maximum continuous thermal load at 23°C).

Maximum switching power

Maximum permissible power switched by the relay contacts, i.e. the product of the switching current and switching voltage.

Mechanical endurance

Number of load free relay switching operations without failure.

Mechanical stress resistance

Characterization of the mechanical stress a relay can withstand during installation or use. The stress resistance is defined in terms of vibration, shock, drop tests, etc.

Minimum recommended voltage

Minimum load voltage to ensure an adequate contact cleaning (see also “fritting”).

Minimum voltage U_{\min} or V_{\min}

Minimum coil voltage at → RT where a relay is still able to operate.

Minimum release voltage (must release voltage)

Voltage at → RT a relay must → release at. To guarantee proper function of all relays, the limit in the car must be below this specified release voltage. Please note that the release voltage of an individual relay, the guaranteed minimum (must) release voltage and the car system value are sometimes all called release voltage.

Monostable and non polarized relay

Monostable: Relay which returns to a defined release state after the coil is de-energized. Non polarized: the relay coil works independently of the polarity of the applied voltage.

Moveable contact

Moving contact during switching operation. Moveable contact is mounted on the armature/spring system.

Glossary

N

NC contact (normally closed)

→ Same as break contact. The break contact is closed in the → release (rest) state of a → monostable relay and opens (breaks) when the armature moves to the core (→ operate state).

Nip-off pin

Removable locking pin of a relay cover ventilation hole. Due to the used plastic materials, an open vent hole is usually not needed for our relays. However, certain extreme ambient/load conditions can generate noxious gases (diffusion, arc ionization) or over-pressure (during SMD soldering) inside a relay, making a gas exchange with the atmosphere desirable.

NO contact (normally open)

→ Same as make contact. Contact is open in the → release (rest) state of a → monostable relay and closes (makes) when the relay coil is energized (→ operate state).

Nominal values (power consumption, voltage)

See → rated values.

Non-operating current/voltage

Coil current/voltage at which an individual relay does not operate.

Non-release current/voltage

Coil current/voltage at which a → monostable relay does not release.

O

Operate

Relay switching process from the release state (→ NC closed) to the operate state (→ NO closed).

Operate state

Switch position of an energized → monostable relay.

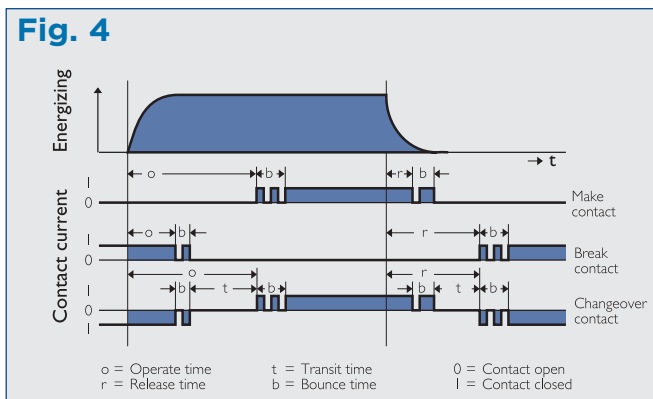

The times given in this catalog are for 12 V coil voltage and RT, without any devices in parallel to the relay coil.

Operate time

Time from energizing the relay coil till the first break of the → NC contact or the first make of the → NO contact. See → relay time characteristics, fig. 4. The operate time is given as a typical value within each section “coil data” in this databook. As the coil resistance depends on the ambient temperature, the operate time varies with the operate voltage and the ambient temperature. For principal behavior see fig. 5.

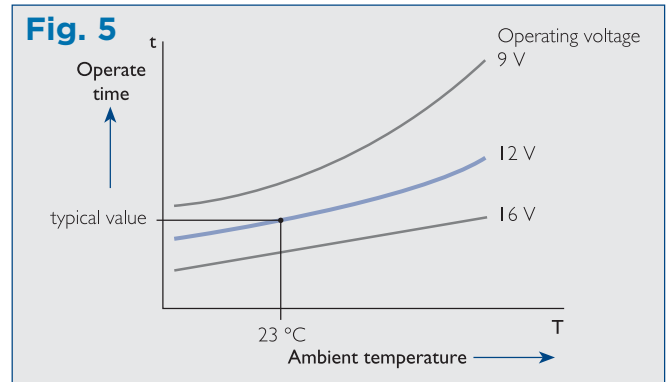

Overload current

This test is done to make sure, that our relays withstand overload conditions, e.g. withstand short circuit conditions until the fuse opens. Current and time are compatible to circuit protection by a typical automotive fuse according to ISO 8820-3 (2002) as shown in the table below. Relay will carry the specified currents at 23°C (I_{rated} = rated current as given in contact data section for each relay).

Test Current in A	Operating time in seconds	
	Minimum	Maximum
6.00 * I_{rated}	0.02 s	0.20 s
3.50 * I_{rated}	0.08 s	0.50 s
2.00 * I_{rated}	0.25 s	5.00 s
1.35 * I_{rated}	0.75 s	1800 s
1.10 * I_{rated}	100 h	No requirement

Table 3

Operate current/voltage/power

Coil current/voltage/power at which a relay operates.

Operation

In tests, a whole switching cycle including energizing and de-energizing of the relay coil.

P

PCB

Common abbreviation for printed circuit board.

PIP

Abbreviation for → pin-in-paste

Glossary

Pin-in-paste (PIP)

Insertion technology for → THR components on a → PCB. The terminals of the component are inserted into printed circuit board holes pre-filled with solder paste.

Polarity reverse

See → H-bridge.
Also see chapter Automotive Applications.

Protection class

According to IEC 529 standard following classification can be carried out for our relays.

Class IP67: Our so called “sealed” relays.

IP6X: Dust-tight. No ingress of dust.

IPX7: Protected against the effects of immersion. Ingress of water in a harmful quantity is not possible when the enclosure is immersed in water under defined conditions of pressure and time.

Class IP54: Non sealed relays which are protected against flux by their base plate and cover.

IP5X: Dust protected. Ingress of dust is not totally prevented, but dust does not enter in sufficient quantity to interfere with satisfactory operation of equipment.

IPX4: Protected against splashing water. Water splashed against the enclosure from any direction shall have no harmful effect.

In addition we classify the following types:

- Flux tight type (open relay without cover)
- Sealed type open vent hole (on top of cover)
- Sealed type tight washable
- Hermetic type

Also refer to Processing Information for → PCB Relays.

Pull-in voltage

Synonym for operate voltage.

R

Rated current

Defined as limiting continuous current at 85°C.

Rated power

Power consumption of the relay coil with → rated coil resistance at rated voltage and → at room ambient temperature.

Rated values (voltage, current, resistance, etc.)

Standard values, the relay is designed for. Values are used to classify relays.

Relay time characteristics

Due to the inertia of a magnetic coil and the limited speed of the armature movement, we distinguish various characteristic relay times as shown in fig. 4.

Release

Switching process of a relay from the → operate state (→ NO closed) to the release state (NO opened or → NC closed).

Release current/voltage

Coil current/voltage at which a → monostable relay releases. Please note that the release voltage of an individual relay, the guaranteed minimum (must) release voltage of a relay type and the car system value are sometimes all called release voltage.

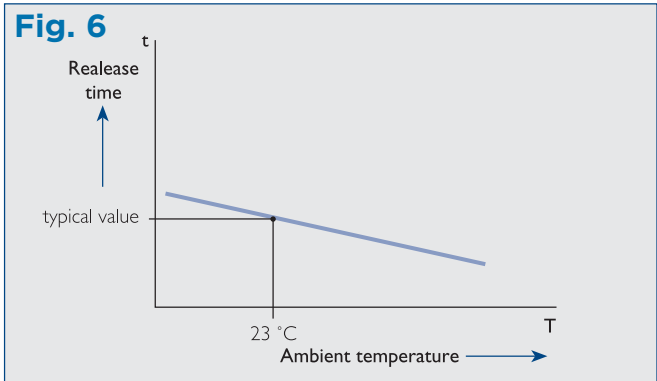

Release state (normal position)

Switch position of a → monostable, non energized relay.

Release time (drop time)

Time interval between de-energizing the coil of a → monostable relay and the first break of the → NO contact or the first make of the → NC contact. The release time is given as a typical value within each section “coil data” in this catalog. As the coil resistance depends on the ambient temperature, the release time varies with the ambient temperature. The influence of the operating voltage can be neglected. For principal behavior see fig. 8. The release time also depends on → coil suppression circuit.

Reset current/voltage

Coil current/voltage at which a → latching relay switches back to the reset position (generally the same value as for the operating voltage).

RoHS

Abbreviation for Restriction of Hazardous Substances.



Room ambient temperature (RT)

A standardized value for the → ambient temperature. In this data book room ambient temperature means 23°C ±3°C.

RT

Abbreviation for room ambient temperature.

Glossary

S

Sealed relay

Relays which are sealed against the penetration of specified → PCB cleaners or lacquers → protection class and refer to chapter Processing Information for PCB Relays.

Shock resistance

The ability of a relay to operate properly during or after mechanical shock acceleration.

Silicone atmosphere

Silicone and its derivatives are not allowed in the material of any relay subcomponent.

Materials containing silicone or its derivatives cannot be used in any form in or near to the processing and packaging of subcomponents and the final relay assembly.

Silicone atmosphere can diffuse through the relay housing and cause contact failures. Substances containing silicone are for example grease and hand cream.

Single contact

Contact configuration with a single → stationary/ → movable contact pair on the make and/or the break side (compare → twin or double contacts).

Single/double pole (single throw version)

A single pole (single throw) relay connects one common line (movable contact) to one load line (stationary contact). A double pole relay switches two, electrically not connected common lines with two electrically independent load lines (like two separate make relays).

Single/double throw (single pole version)

A single throw (single pole) relay connects one common line (movable contact) to one load line (stationary contact). A double throw (single pole) relay switches one common line between two → stationary contacts, for example between a → NO contact and a → NC contact (→ changeover relay or form C).

Spark suppression

Reduction of the → arc energy between → movable and → stationary contact during switching.

Stationary contact

Non movable contact, mounted on a → contact carrier which is directly connected to a relay pin/faston blade.

Steady state current limit

See → limiting continuous current.

Storage

Relays should be stored in a clean area within the specified temperature limits. Extreme humidity and condensation can cause corrosion of the metal parts in and outside of the relay. Solderability is best within a storage period of up to 6 months under 15 to 35°C; 25 to 75% relative humidity, according to IEC 68. SMT relays have to be dried before the soldering process to prevent damage caused by evaporating humidity absorbed in the plastic. This is done in the preheating zone of the SMD oven. Temporarily increased contact resistance caused by the formation of oxides and other layers during a longer storage period, is typical for most contact materials.

The growth of such layers depends on the ambient atmosphere and is more rapid at high temperature. Special attention is required if relays are tested or used with low contact loads after extended storage periods. See also “Diagnostics of Relays” in the Application Notes.

Surface mounted device (SMD)

See surface mount technology (SMT).

Surface mounted technology (SMT)

An assembly process where electrical connection of components → (surface mount device) is made to the surface of a conductive pattern of a PCB without component terminal holes. SMT soldering should be carried out according to the recommendations of CECC 00802 and IPC/JEDEC J-STD-020C if not stated otherwise in the respective datasheet.

Switching current

Current switched by the relay contact.

Switching rate

Number of → operations (contact closings and openings) per second. The rated “maximum switching rate” is measured for load free switching at → room ambient temperature and no → coil suppression device parallel to the coil.

Switching voltage

Voltage between the relay contacts before closing or after opening the contacts.

Switch off voltage peak of the relay coil

Induced voltage peak caused by the collapsing magnetic field of a de-energizing relay coil. The product of the coil current and the resistance* of the device parallel to the coil approximately gives the amplitude of the switch off voltage.

* In case of a 36 V rated coil the use of a 60 V Varistor or Zener diode is recommended.

Glossary

T**Test voltage/dielectric test voltage/dielectric strength**

Voltage applied during dielectric (high voltage) tests between intentionally not electrically connected parts of the relay.

Thermal resistance

Relay parameter measured in Kelvin per Watt, which relates the consumed power with the respective temperature increase in thermal equilibrium.

Without load and parallel resistor, the thermal resistance of a coil multiplied with its power consumption (at the actual coil temperature) gives the temperature increase of the coil above ambient temperature.

Through-hole technology (THT)

An assembly process for mounting components where terminals are passed through supported (plated through) or unsupported (bare) holes in an interconnection substrate. Normally, traditional wave soldering is used with THT components.

Through-hole reflow (THR)

An assembly process, where THT components are soldered in a reflow process instead of traditional wave soldering. See also → pin-in-paste and for details see chapter Processing Information.

Transit time

The movement time of the armature after opening of one contact set (e.g. NC) before closing of the other (e.g. NO) of a → changeover relay (→ relay time characteristics, fig. 4).

Triple make contact, Form 3

Three make contacts configuration (new form) with three electrically connected movable contacts operating simultaneously. There is no external connection to the armature. See also table 1.

V**Vent hole open (open vent hole)**

Reflow solderable relays as well as THR and SMD relays are provided with an open vent hole on top of the cover.

Vibration resistance

The ability of a relay to maintain the operating state during mechanical vibration.

Voltage drop/voltage mV drop

See → contact/relay resistance.

W**WEEE**

Abbreviation of Waste Electric and Electronic Equipment.

Relay Contact Life

Relay contacts are available in a variety of metals and alloys, sizes and styles. There is no such thing as a universal contact. The relay user should select contact materials, ratings, and styles to meet, as precisely as possible, the requirements of a particular application. Failure to do so can result in contact problems and even early contact failure.

For example, some contact materials require an arc to keep them free of sulfidation, oxidation, and contaminants. Such materials on contacts used in a dry or low-level circuit can result in the contacts failing electrically to close the circuit, even though they make physically. The contacts may look clean, but this is deceiving. In reality, there is a very thin film of insulating sulfidation, oxidation or contaminants on the surface of the contacts. This film must be removed for circuit continuity to be established, and arcing can accomplish this. (For dry and low-level circuits, bifurcated contacts should be used.)

Applications Considerations

In some applications, the contacts may be subjected to punishing current surges which can drastically reduce their life. Consider an incandescent lamp. A 40 watt, 120V AC lamp has a current rating of .33 ampere. The resistance of the filament when cold, however, is so low that initial inrush current may be as much as 6 amps! To attempt to switch the 40 watt lamp with, say 2 amp contacts will result in early contact failure.

The same situation exists in motor and transformer applications, and in applications where significant distributed line capacitance exists. During start-up, a motor can pull 600% or more of its running current. Thus, a 3 amp motor may actually pull 18 amps or more during start-up. A contact rated at least 20 amps should be used. Additionally, when disconnected, a motor acts as a voltage generator as it slows to a stop. Depending on the motor, it can feed back into the circuit voltages well in excess of rated line voltage. These voltages appearing across the separating contacts can cause a destructive arc to exist between the contacts, which can lead to early failure of the contacts. Because of this, it is desirable to suppress the arc. (Techniques for arc suppression are discussed later in this application note.)

Transformers can present an unusual trap for an unsuspecting relay user. When power is removed from a transformer, its core may contain remanent magnetism. If power is reapplied when voltage is of the same polarity as that of the remanent magnetism, the core may go into saturation during the first half-cycle of reapplied power. As a result, inductance will be minimal and an inrush current of perhaps 1,000% may exist for a few cycles until the core comes out of saturation. Worse, if reapplied power occurs at or near zero voltage and the increasing voltage aids remanent magnetism, the core **and** the air gap may saturate. An inrush of perhaps **4,000% or more** may result! Also, as with motor loads, when power is removed from a transformer, the transformer will develop a counter voltage which can cause a destructive arc to exist between separating contacts.

Distributed line capacitance presents particular problems for relays and their contacts. This occurs when a relay is located a considerable distance from the load to be switched. The instant the contacts close, distributed line capacitance charges before load current flows. This capacitance can appear as an initial short-circuit to the contacts, and can pull a current well in excess of load current. Prior to selecting a relay to switch a circuit when distributed line capacitance may be significant, instantaneous inrush current should be measured, and contacts selected accordingly.

Contact Materials

Fine Silver

Fine silver has the highest electrical and thermal properties of all metals. It is the best general purpose material available. However, it is affected by sulfidation. The rate of sulfidation indoors in a metropolitan area is approximately 70 micrograms per square centimeter per day. This sulfidation forms a film on the surface of the silver which increases contact interface resistance.

Because silver and silver alloys sulfidate, contact pressures must be great enough to break through this film. (Controlled arcing will also be helpful in that it burns off the sulfidation, and contact overtravel wipes away the residue.) While such pressures have no appreciable effect on silver-cadmium contacts, they do result in increased material wear of fine silver contacts. Also, an interface voltage of several tenths of a volt can result with fine silver contacts because of the sulfide film. This film has been known to capture and imbed airborne dirt. Breaking through this film generates electrical noise. Because of this, fine silver contacts are not used for low-level switching, such as audio circuits. Rather, fine silver and silver alloy contacts are for use in circuits of 12 volts, 0.4 ampere, or more.

Gold-Flashed Silver

For relays which must sit idle for long periods of time before initial operation, sulfidation of silver contacts can result in an impregnable contact interface resistance. Instead of specifying silver contacts for such applications, gold-flashed silver contacts should be specified. Gold flashing on each contact results in minimal sulfidation, and provides good electrical make upon contact. Because gold has a low boiling temperature, the flashing will burn off after just a few switch cycles if arc voltage and current is exceeded. The silver underlayer is then exposed, and may develop a sulfide film. Unless this situation can be tolerated, gold-flashed contacts should not be subjected to arcing.

Gold Overlay

A common contact for use in dry-and low-level circuits is gold overlay. The overlay is of sufficient thickness that it should not wear through to the base metal unless subjected to arcing conditions.

Silver Nickel

Depending on the application, material transfer may be quite prevalent with fine silver contacts. Typically, material tends to accumulate in the center of one contact, while the loss of material on the other contact leaves a hole, or "pit." This pitting may cause premature contact failure. In such an application, it may be desirable to use fine grain silver contacts. These contacts are alloyed with 0.15% nickel, which gives the contacts a fine grain structure. As a result, material transfer is evenly distributed across the entire surface of the contact and the contacts last longer.

Silver Cadmium Oxide

Silver cadmium oxide contacts have long been used for switching loads that produce a high energy arc. Silver cadmium oxide contacts are less electrically conductive than fine silver contacts, but have superior resistance to material transfer and material loss due to arcing. They do exhibit greater interface resistance between mated contacts, and also a slightly greater contact assembly heat rise. The minimum arc voltage rating of silver cadmium oxide is 10 volts and, like fine silver contacts, the silver in this alloy will oxidize and sulfidate. Therefore, an arc is necessary to keep these contacts clean.

Silver Tin Indium Oxide

Silver tin indium oxide contacts, although not readily available, exhibit better resistance to arc erosion and welding than silver cadmium oxide contacts. They are even less electrically conductive, though, and are harder than silver cadmium oxide contacts. They have greater interface resistance between mating contacts and, therefore, a greater voltage drop and heat rise. At the present time, silver tin indium oxide is more expensive than silver cadmium oxide, and many relay users limit its use to applications such as incandescent lamp loads and capacitors where there is a massive inrush current during contact bounce. For low and medium power resistive and inductive loads, silver cadmium oxide is still the most commonly used and is recommended by Siemens Electromechanical Components (SEC). For applications where it is believed that silver tin indium oxide should be used, contact SEC applications engineering.

Silver Copper Nickel

Silver copper nickel contacts are for use in high inrush DC applications

such as incandescent lamps and capacitive loads. These contacts exhibit good resistance to welding.

Gold Silver Nickel Alloy

Gold silver nickel alloy contacts are for use in switching loads generally of less than one ampere, and are characterized by less electrical noise on make and break than fine silver contacts. Gold diffused silver contacts offer characteristics similar to gold silver nickel alloy, but are less expensive.

Palladium

Palladium contacts do not sulfidate or oxidize, and so offer extremely low electrical noise levels. They have an electrical life expectancy of approximately 10 times that of fine silver contacts. However, because of relatively poor conductivity properties, load currents are limited to about 5 amperes.

Palladium contacts require .006" to .012" overtravel to insure good wiping action. Because of this, they are used primarily on telephone-type relays—that is, relays on which the contact arms are parallel to the length of the coil, and on which such overtravel is easy to obtain. Also, palladium contacts should be bifurcated to help insure circuit continuity on contact closure.

Tungsten

Tungsten contacts are for use in high voltage applications, usually where highly repetitive switching is required. Tungsten has a melting temperature of 3,380°C which gives it excellent arc-erosion resistance.

Tungsten may develop troublesome oxide films, especially when used as the anode contact in some DC applications. Therefore, tungsten is often used as the cathode contact, and a palladium alloy used as the anode contact. Such a combination also minimizes contact interface resistance and material transfer.

Mercury

Mercury has a melting temperature of -38.87°C. Thus, as used in relays, it is in a liquid state. Mercury will cling to the surface of any clean metal, and is used as the contacts in mercury-wetted reed relays. It has good electrical conductivity and, being liquid, there is no material transfer build-up from contact to contact. Any such material transfer is negated by the fact that when the contacts open and the mercury returns to the pool in the bottom of the relay, fresh mercury takes its place at the very next switch operation. Mercury has a boiling temperature of 357°C. Because of this, mercury contacts cannot switch currents of more than a few amperes.

Contact Life

The electrical life expectancy of general purpose and power relays is generally rated to be 100,000 operations minimum, while mechanical life expectancy may be one million, 10, or even 100 million operations.

The reason electrical life is rated so low compared with mechanical life is because contact life is application dependent. The electrical rating applies to contacts switching their rated loads. When a set of contacts switches a load of less than rated value, contact life may be significantly greater. For example, 25 amp, 240V AC, 80% P.F. contacts may be expected to switch such a 25 amp load in excess of 100,000 operations. If these contacts are used to switch, say, a 5 amp, 120V AC resistive load, however, life may be in excess of a million operations. Rated electrical life also takes into consideration arc destruction of the contacts. By use of appropriate arc suppression, contact life may be lengthened. Table 1 lists some arc voltage and current values for several different metals. An arc will ignite if both minimum arc voltage and current

**Table 1 -
Characteristics of Various Contact Materials**

Material	Electrical Conductivity %IACS	Melt Voltage	Arc Voltage	Arc Current
Cadmium	24		10	0.5
Copper	100	0.43	13	0.43
Gold	77	0.43	15	0.38
Nickel	25	0.65	14	0.5
Palladium	16	0.57	15	0.5
Silver, fine	105	0.37	12	0.4
Tungsten	31	0.75	15	1.0

are exceeded. However, there will be no arc if load current at a given minimum arc voltage is less than the minimum arc current for that voltage. Likewise, there will be no arc if load voltage (or counter emf) is less than the minimum arc voltage of the contact metal.

As stated, an arc may be necessary in order to burn off the contacts any sulfidation, oxidation or contaminates. However, by its very nature, an arc is destructive. For maximum contact life, the arc should be suppressed as quickly as possible as soon as it ignites. Such arc suppression may be accomplished using techniques presented in this application note.

At voltage and current values of less than those required to ignite an arc, a spark may occur between separating contacts. This spark is a capacitive discharge, and is weak compared with an arc. Even so, the spark may be sufficient to keep sulfidation, oxidation, and contaminates from building up on the contacts. (Note: arc suppression has little, if any, effect on contact sparking.)

Contact life is terminated when the contacts stick or weld, or when excessive material is lost from one or both contacts and a good electrical make is not possible. These conditions are the result of cumulative material transfer during successive switching operations, and of material loss due to splattering.

Material Transfer and Material Loss

Material transfer occurs as a result of I^2R heat. As switch contacts begin to separate, the area of contact diminishes. Load current flowing through this increasingly constricted area generates heat which causes the contact material to melt, then boil. The liquified metal tends to collect on the cathode contact because that contact is cooler than the anode contact. Material transfer also occurs during arcing. However, under this condition, material transfer is from cathode to anode—the amount of transfer being dependent on the severity and duration of the arc, and the type of contact material used. Because contact material migrates first one way, then the other, the ideal arc suppression technique would be to quench the arc just as the anode recovers all of the material lost to the cathode just prior to the arc striking. However, this is impractical even to attempt.

Material **loss** is due primarily to splattering of the molten and boiling metal as contacts bounce on make. Such loss can be significant over the course of tens of thousands of operations, and the only practical way to minimize it is by arc suppression. Arc suppression quickly quenches the arc, thereby holding contact temperatures lower.

In DC applications, metal migration is predictable in that one contact is always negative, and the other, positive. In AC applications where switching is at random, either contact may be negative or positive when arcing occurs. Migration will not be in the same direction each time the switch opens, and material loss from either contact should not be significant—unless load conditions cause splattering.

Not all AC applications incorporate random switching, however. In some applications, the relay is operated at a set rate or frequency. In such instances, the contacts break load current at the same approximate point on the sine wave. That is, the same contact is always positive, and the other negative at the instant of contact separation. Material transfer during arcing will always be in the same direction. In such applications, contact arc suppression may be necessary.

This is not to say that arc suppression is not needed on random-switching AC applications. On the contrary, arc suppression can help control the loss of contact material due to splattering of the molten metal. That is, when the arc is suppressed, contact temperature is held to a minimum.

Controlled arcing of short duration can be beneficial in actually achieving the rated life of the contacts. As stated, this is because such arcing burns off of the contacts any deposits that might prevent electrical make. Such control is achieved by arc suppression. Unless arcing and/or contact overtravel cleans the contacts, films may develop on the contact surfaces, or foreign matter may collect. For this reason, it is best to apply general purpose and power relays only in applications where load voltage (or counter emf) and current is in excess of the arc voltage and current ratings of those contacts.

Contact Protection

Perhaps the most popular method of quenching an arc between separating contacts is with an R-C network placed directly across the contacts. As the contacts just begin to separate and an arc ignites, load

current feeding the arc will be shunted into the capacitor through the series resistance, depriving the arc of some of its energy. As a result, arc duration will be shortened and material loss will be minimized.

Contact Protection Diagram

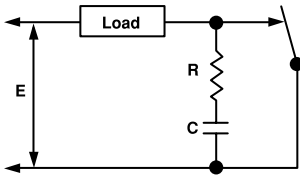

Theoretically, the ideal arc suppression method would simply be a capacitor placed directly across the contacts. However, with no resistor in the circuit, when the contacts make, there is nothing to limit capacitor discharge current. This nearly instantaneous discharge current can generate a brief, but severe arc that may cause welded contacts, depending on contact material and characteristics. Thus, the resistor is necessary to limit capacitor discharge current. However, there is one drawback. That is, the resistor tends to isolate the capacitor from the very contacts the capacitor is supposed to protect. Because of this, the amount of resistance should be kept as small as possible.

Many relay users are unfamiliar with the selection of a capacitor for arc quenching service. To begin with, AC differs from DC in that AC crosses zero 120 times per second for 60 Hertz service while DC, of course, is continuous current. In AC service, the capacitor need not be as large as in DC service because the AC arc will extinguish at a zero crossover point. In DC service, the capacitor must continue to shunt load current away from the contacts until the contacts separate far enough apart for the arc to extinguish.

Capacitor Selection

Assume a DC application of 28 volts, 5 amperes. Further assume an R-C network is needed that will result in contact voltage of perhaps 15 volts 1 μsec. after the contacts have separated. Since the value of resistance should be as small as possible, a 2 ohm resistor might be chosen. At 2 ohms, peak capacitor discharge current will be 14 amperes at time zero. Depending on contact material and size, this 14 amperes may be quite acceptable for such a short period of time.

Contact voltage—that is, arc voltage—at any given instant of time is simply the sum of the voltage drop of the resistor and the capacitor voltage. Select a capacitor voltage of, say, 10 volts. The remaining 18 volts must appear across the 5.6 ohm load and the 2 ohm resistor. Thus, instantaneous capacitor current is:

$$I = \frac{E}{R} = \frac{18V}{7.6\Omega} = 2.4 \text{ ampere,}$$

and the voltage drop of the 2 ohm resistor is 4.8 volts. Arc voltage, therefore, one microsecond after contact separation is 4.8V + 10V = 14.8V, or about 53% of supply voltage.

To determine the size of capacitance needed, the basic equation for capacitor voltage may be used:

$$e_c = E(1 - e^{-t/RC})$$

Rearranging the equation to solve for capacitance gives 1.1 μfd.

$$C = \frac{-t}{[I_n(1 - \frac{e_c}{E})]R} = 1.1 \times 10^{-6} \text{ farad}$$

Where: t = 1 μsec.
 e_c = 10 volts = capacitor voltage at time t.
 E = 28 volts (for AC, use peak value).
 R = 2.0 ohms.

The next question concerns capacitor construction. Can the capacitor withstand discharge surge currents? When the contacts close, the capacitor will discharge through the resistor. For a 1 μfd. capacitor and a 2 ohm resistance, the time constant is: R x C = 2 x 1 μfd. = 2.0 μsec.

To determine discharge di/dt:

$$i = C \frac{dv}{dt} = 1 \times 10^{-6} \frac{28 \times .63}{2.0 \times 10^{-6}} = 8.8A_{avg}/\mu\text{sec.}$$

where: .63 is the capacitor voltage loss during one time constant of 2.0 μsec.

This di/dt isn't very severe and a wide variety of capacitors should be able to withstand it. However, the di/dt of a 5 ampere 240 volt AC application would be 107A/μsec. at peak of the AC line—that is, 340 volts; and capacitor selection* should be made accordingly.

Of course, di/dt may be lowered by a larger value of resistance to limit capacitor discharge current even more. But, the greater the value of resistance, the less effect the capacitor has on the arc.

Other Arc Suppression Methods

For quenching DC arcs in certain applications, relays are available that have a permanent magnet located in close proximity to the contacts. The magnet repels the DC arc, thereby stretching the arc and causing it to extinguish quickly.

Some relay users connect a diode across the inductive load to prevent countervoltage from reaching the contacts. When the relay contacts open, the stored energy of the inductance recirculates through the diode, not through the arc. While this is an acceptable method of protecting the contacts, it does result in lengthened hold-up time of the inductive load. For those applications that cannot tolerate lengthened hold-up time, a resistor may be placed in series with the diode. The resistor does, however, lessen the effectiveness of the diode and, usually, a compromise must be reached by trial and error.

By using a zener diode in place of the resistor, hold-up time is greatly reduced. This is because the diodes cannot turn on until the voltage across them equals the sum of their voltage drops.

In some circuits, space is at a premium and there may not be sufficient room for a zener and a regular diode. In such circuits, some designers use a metal oxide varistor. The MOV performs in a manner similar to back-to-back zener diodes. And, since the MOV is a bidirectional device, it can be used in both AC and DC circuits.

An added benefit of arc suppression is the minimization of EMI. An unsuppressed arc between contacts is an excellent noise generator. Such noise can be troublesome to sensitive components in a circuit, or within the RFI field. In worst-case conditions, EMI can cause unwanted turn-on of IC logic gates, SCRs, and triacs, and can cause damage to other semiconductor devices.

*Suggested capacitor atypes are metallized foil and film foil. Check capacitor specifications for dv/dt and di/dt ratings.

Application Notes

- Measure the current inrush of the circuit to be switched before specifying the relay.
- Never parallel relay contacts to double the contact rating. Unless the relays are specially adjusted, they will not pick up and drop out simultaneously. Even if they were to be specially adjusted, they would not hold this adjustment over life.
- Paralleling Form C contacts may result in an unwanted make-before-break arrangement.
- Contacts rated low level to 2 amps may be used to switch a 2 amp load. Once having done so, however, they cannot be used to switch reliably a low level load.
- In a circuit comprising a series of open relay contacts (AND logic), all but the last set of contacts to close will be dry. Likewise, in a circuit comprising a series of closed contacts, all but the first to open will be dry.
- The use of many relay contacts in series may be limited by total circuit contact resistance.
- A "low level" circuit that pulls a capacitive inrush current or develops an inductive counter emf is not low level. Worst case circuit conditions dictate contact rating, not steady state conditions.

Temperature Considerations for DC Relays

Relays and temperature are intertwined. When a relay is exposed to various temperatures, its operating characteristics change dependent upon the temperature. The most notable changes occur in the pick-up voltage (V_{pi}) and coil resistance (R_c). The coil winding of a relay is produced with copper wire and thus the coil resistance varies with the temperature coefficient of copper. For the temperature range that a relay will normally be exposed to, the change in copper follows the form of:

Eqn. 1

$$R_1 = R_0 \times (1 + A \times (T_1 - T_0))$$

where: R_1 = Resistance at temperature T_1

R_0 = Resistance at temperature T_0

A = Slope of a line from a point (-234.5,0) through the point (T_0 , 1) ($A = 0.003929$ at $T_0 = 20^\circ\text{C}$)

T_1 = New temperature of interest

T_0 = Reference temperature (20°C is typically used for this value)

Now that we can calculate the coil resistance at a new temperature given a value at some known reference temperature, let us look at the pick-up voltage. For a DC relay, the magnetic force developed is proportional to the Ampere-turns developed in the coil. Since the mechanical forces are fairly constant over the normal temperature range (and the number of turns is fixed), we can also deduce that the pick-up current (I_{pi}) will be constant. If pick-up current is constant and coil resistance varies, it follows that pick-up voltage ($V_{pi} = I_{pi} \times R_c$) varies directly as the coil resistance. This leads to a simple mathematical method to determine coil resistance and pick-up voltage at any temperature if a reference point is known.

For example:

Assume that a relay has the following parameters at 20°C (T_0).

$$R_c = 90 \text{ Ohms}$$

$$V_{pi} = 6.5 \text{ volts}$$

Calculate the new coil resistance at 105°C (T_1)

From Eqn. 1 we find:

$$\begin{aligned} R_1 &= 90\Omega \times (1 + 0.003929/^\circ\text{C} \times (105^\circ\text{C} - 20^\circ\text{C})) \\ &= 90\Omega \times (1.334) \\ &= 120.1\Omega \end{aligned}$$

Eqn. 2

To find the new pick-up voltage, we replace R_1 and R_0 with V_1 and V_0 respectfully to find:

$$\begin{aligned} V_1 &= 6.5 \text{ volts} \times (1.334) \\ &= 8.67 \text{ volts} \end{aligned}$$

To find the factor, A , the following equation is provided:

$$A = 1 / (T_0 + 234.5)$$

For three common reference temperatures, A is as follows:

European & Asian at 20°C :	$A = 0.003929$
International (IEEE) at 23°C :	$A = 0.003883$
United States at 25°C :	$A = 0.003854$

It is not a critical matter which reference temperature is used. The international was selected as 23°C ($\pm 3^\circ\text{C}$) to encompass both of the previous standards and thus appease everyone. It is recommended that this value be used whenever specifying new products since it is not more than 1.2% from either the 20 or 25°C reference and will provide future consistency if adopting ISO countries begin to utilize it. The equivalent values can be calculated from this reference for the others. Not that almost all European specifications still use the 20°C reference while many U.S. firms are beginning to utilize the 23°C reference.

While temperature changes affect relay parameters, the power dissipated within the relay also affects the temperature in most applications. The power dissipated within the relay may be broken down into two major components. The first is heat generated in the relay coil when voltage is applied to it. This heat creates a temperature rise (or increase) in the relay coil and package. The amount of temperature rise created is dependent upon several factors such as the volume of copper wire used, insulation thickness, insulation type, bobbin material, bobbin thickness, terminal size, conductor size, and several other factors that are design related. Each of these factors will either enhance or resist the flow of generated heat out of the coil assembly and into the ambient air. For a given relay design, these factors can be summed together into a value called the "coil to ambient thermal resistance" of the relay. The dimensions of such a value are $^\circ\text{C}/\text{Watt}$. The thermal resistance is analogous to the electrical resistance and the temperature rise created by coil power dissipation follows the equation:

Eqn. 3

$$T_{RC} = \theta_{CA} \times P_D$$

where: T_{RC} = Temperature rise caused by coil dissipation

θ_{CA} = Thermal resistance from coil to ambient

P_D = Final steady-state power dissipated in coil

For normal relay temperature ranges, this relationship is nearly linear and consistent under the following conditions:

1. The relay is in still air and not subjected to significant air flow or the value of θ_{CA} was determined with an air flow identical to the end application (difficult to simulate). For pc board relays, the still air assumption is often valid because of the end product enclosure.
2. All power calculations deal with the coil resistance at the final coil temperature (T_c) attained. If only room temperature coil resistance were used, the resulting non-linearity would result in significant errors at higher temperatures.
3. The value for thermal resistance is determined from test data where the relay carried no load current.

We now have the information necessary to calculate the final coil temperature from data book parameters under no load conditions for a relay. Let us try an example.

Given the following:

$$\begin{aligned} T_0 &= 20^\circ\text{C} \\ V_0 &= V_{pi} = 6.8 \text{ volts} \\ R_0 &= 90 \text{ Ohms} \\ V_A &= 13.5 \text{ volts } (V_A = \text{applied coil voltage}) \\ \theta_{CA} &= 40^\circ\text{C}/\text{W} \\ T_A &= 85^\circ\text{C} (T_A = \text{ambient temperature}) \\ I_L &= 0 \text{ Amperes } (I_L = \text{load current}) \end{aligned}$$

Determine the following:

1. "Cold start" pick-up voltage (with the coil previously unenergized) and coil resistance at T_A
2. Final steady-state coil temperature (T_C) and resistance for V_A
3. "Hot start" pick-up voltage (after coil energized at V_A) at T_A and V_A

First we solve Eqn. 1 for R_1 at 85°C

$$\begin{aligned} R_1 &= 90 \times (1 + 0.003929 \times (85 - 20)) \\ &= 90 \times (1.2554) \\ &= 113.0 \text{ Ohms} \end{aligned}$$

Again we find V_1 at 85°C by using the same factor

$$\begin{aligned} V_1 &= 6.8 \times (1.2554) \\ &= 8.54 \text{ volts} \end{aligned}$$

Now the difficult part, finding T_C with 13.5 volts applied to the coil.

From Eqn. 3, and realizing that $T_C = T_A + T_{RC}$ and $P_D = V_A^2 / R_C$:

Eqn. 4

$$T_C = \theta_{CA} \times V_A^2 / R_C = T_A$$

Now we have a problem. As we have already seen, R_C changes with temperature. Since we are calculating temperature, we have two variables. The easiest approach to use here is simple iteration. Let us start by using the initial coil resistance at the ambient temperature of interest:

$$\begin{aligned} T_{C1} &= (40 \times ((13.5)^2 / 113)) + 85 \\ &= 64.5 + 85 \\ &= 149.4^\circ\text{C} \end{aligned}$$

We must now calculate a new value of R_C using T_{C1} and Eqn. 1.

$$\begin{aligned} R_{C1} &= 90 \times (1 + 0.003929 \times (149.5 - 20)) \\ &= 90 \times (1.5088) \\ &= 135.8 \text{ Ohms} \end{aligned}$$

Now using Eqn. 4 again;

$$\begin{aligned} T_{C2} &= (40 \times ((13.5)^2 / 135.8)) + 85 \\ &= 53.7 + 85 \\ &= 138.7^\circ\text{C} \end{aligned}$$

Again we would calculate a new value of R_C at T_{C2} and repeat the process until a sufficient accuracy is obtained. With several iterations, the answer to this example becomes:

$$T_C = 140^\circ\text{C}$$

Now that we have the final coil temperature, we can find the coil resistance with Eqn. 1.

$$\begin{aligned} R_C &= 90 \times (1 + 0.003929 \times (140 - 20)) \\ &= 90 \times (1.4715) \\ &= 132.4 \text{ Ohms} \end{aligned}$$

The "hot start" pick-up voltage is found using the same factor:

$$\begin{aligned} V_1 &= 6.8 \times (1.4715) \\ &= 10.0 \text{ volts} \end{aligned}$$

The only remaining piece to the puzzle is how a contact load current affects the temperature of the relay coil and thus its parameters. Past

studies imply that the contact power dissipation may be treated as a separate heat source that adds heat into the relay package. Its effect on coil temperature is dependent upon many factors including package size, contact to coil distance, contact terminal size, connecting wire size, shared thermal paths, etc. Again, these factors can be lumped into a contact to coil thermal resistance. This leads to an equation similar to Eqn. 3.

Eqn. 5

$$T_{RL} = \theta_{CC} \times P_K = \theta_{CC} \times R_K \times I_L^2$$

where: T_{RL} = Temperature rise in coil caused by the load current

θ_{CC} = Thermal resistance from contact to coil

P_K = Power dissipated in contacts

R_K = Contact circuit resistance

I_L = Load current flowing through the contact circuit

As an alternative possibility, and in an effort to provide a best fit curve to earlier test data, the following equation has yielded good approximations.

Eqn. 6

$$T_{RL} = K_{RL} \times I_L^{1.85}$$

This formula has been empirically derived from several test results and has successfully predicted final coil temperature rise caused by contact loads. The value K_{RL} can be derived from a two step temperature test. First determine temperature rise with no contact load and then measure under the same conditions with a contact load. The coil temperature rise minus the part caused by the coil power dissipation yields a T_{RL} and I_L combination that may be used to solve Eqn. 6 for K_{RL} .

The final coil temperature is then found by adding the respective components to obtain:

Eqn. 7

$$\begin{aligned} T_C &= T_A + T_{RC} + T_{RL} \\ &= T_A + \theta_{CA} \times (V_A^2 / R_C) + K_{RL} \times I_L^{1.85} \end{aligned}$$

This formula also requires solution by iteration. Since the only difference here is the added T_{RL} term, the following example is left to the reader.

All conditions the same as in the previous example except with:

$$\begin{aligned} I_L &= 20 \text{ Amperes} \\ K_{RL} &= 0.029 \end{aligned}$$

The answers should be 113.0 Ohms, 8.54 volts, $T_C = 146.5^\circ\text{C}$, $R_1 = 134.73$ Ohms, and $V_1 = 10.18$ volts.

The reader should now be able to determine the steady-state characteristics for any temperature and voltage combination given the appropriate relay data. It must be stressed that the values obtained here apply to DC relays operated continuously at these values. Intermittent duty (with short, i.e. less than 1 minute, "on" times and longer "off" times) may result in substantially lower temperatures. Therefore if a specific known duty cycle is given for the relay operation, testing at these conditions could yield acceptable results for final coil temperature when the continuous duty temperatures calculated here would not. The methods discussed here are applicable to standard DC relays and while the coil resistance formula will work for Polarized DC relays (one that utilizes a permanent magnet) and AC relays as well, the pick-up voltage equations will not work in such cases. With a polarized DC relay the temperature induced change in magnetic force of the magnet must be considered. This is normally such that it reverses part of the change in pick-up voltage caused by the copper wire resistance. In the case of AC relays, the inductance contributes a significant portion of the coil impedance and is related to the turns in the coil. since the inductance varies only slightly with temperature, the pick-up voltage exhibits less variation over temperature than for DC relays.

The application of relay coil suppression with DC relays

This application note has been written in response to the numerous application problems resulting from improper relay coil suppression. The typical symptom is random "tack" welding of the normally-open contacts when switching an inductive load or a lamp load with high inrush current.

The Need for Transient Suppression

When an electromechanical relay is de-energized rapidly by a mechanical switch or semiconductor, the collapsing magnetic field produces a substantial voltage transient in its effort to disperse the stored energy and oppose the sudden change of current flow. A 12VDC relay, for example, may generate a voltage of 1,000 to 1,500 volts during turn-off. With the advent of modern electronic systems, this relatively large voltage transient has created EMI, semiconductor breakdown, and switch wear problems for the design engineer. It has thus become common practice to suppress relay coils with other components which limit the peak voltage to a much smaller level.

Types of Transient Suppression Utilized with Relays

The basic techniques for suppression of transient voltages from relay coils are shown in Figure 1. As observed here, the suppression device may be in parallel with the relay coil or in parallel with the switch used to control the relay. It is normally preferred to have the suppression parallel to the coil since it can be located closer to the relay (except in the case of PC board applications where either may be used).

When the suppression is in parallel with the relay coil, any of the following may be used.

- A. A bilateral transient suppressor diode that is similar in V-I characteristics to two zener diodes connected cathode to cathode (or anode to anode).
- B. A reverse-biased rectifier diode in series with a zener diode such that their anodes (or cathodes) are common and the rectifier prevents normal current flow.
- C. A metal-oxide-varistor (MOV).
- D. A reversed-biased rectifier diode in series with a resistor.
- E. A resistor, when conditions permit its use, is often the most economical suppression.
- F. A reversed-biased rectifier diode.
- G. A resistor-capacitor "snubber". Generally the least economical solution and no longer considered a practical solution.
- H. A bifilar wound coil with the second winding used as the suppression device. This is not very practical since it adds significant cost and size to the relay.

Suppression used in parallel with the switching element is likely to be either a zener diode or a resistor-capacitor "snubber". The comments associated with the "parallel to coil" application are also applicable to this circuit.

Figure 1 - Schematic for Relay Coil Suppression

Suppressor Parallel to Coil

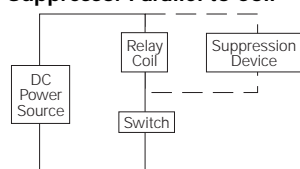

Suppressor Parallel to Switch

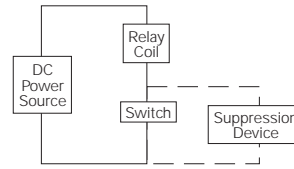

Effects of Coil Suppression on Relay Dynamics and Life

Even though the use of coil suppression is becoming more significant, relays are normally designed without taking the dynamic impact of suppressors into account. The optimum switching life (for normally-open contacts) is therefore obtained with a totally unsuppressed relay and statements of rated electrical life are usually based on this premise. The successful "breaking" of a DC load requires that the relay contacts move to open with a reasonably high speed.

A typical relay will have an accelerating motion of its armature toward the unenergized rest position during drop-out. The velocity of the armature at the instant of contact opening will play a significant role in the relay's ability to avoid "tack welding" by providing adequate force to break any light welds made during the "make" of a high current resistive load (or one with a high in-rush current). It is the velocity of the armature that is most affected by coil suppression. If the suppressor provides a conducting path, thus allowing the stored energy in the relay's magnetic circuit to decay slowly, the armature motion will be retarded and the armature may even temporarily reverse direction. The reversing of direction and re-closing of the contacts (particularly when combined with inductive loads) often leads to random, intermittent "tack welding" of the contacts such that the relay may free itself if operated again or even jarred slightly.

Based upon the impact on armature motion and optimizing for normally-open contacts, the best suppression method is to use a silicon transient suppressor diode. This suppressor will have the least effect on relay drop-out dynamics since the relay transient will be allowed to go to a predetermined voltage level and then permit current to flow with a low impedance. This results in the stored energy being quickly dissipated by the suppressor. Transient suppressor diodes are available as bi-directional components and permit the relay to be non-polarized when installed internally. Note that if a uni-directional transient suppressor is used, a rectifier diode must be placed in series with it to block normal current flow and it has little advantage over the use of a zener diode. The transient suppressor should be selected such that its pulse energy rating exceeds any anticipated transient such as coil turn-off or motor "noise" found in the application.

A metal-oxide-varistor will provide results similar to those of transient suppressor diode, but will have a higher "on-state" impedance and will thus allow a higher voltage to be developed. As an example, a 33 volt transient suppressor diode may have a "clamping" voltage between 30 and 36 volts. In comparison, a 33 volt MOV will likely clamp the relay at 45 to 55 volts (based on a typical automotive relay with 130 mA coil current). When the additional voltage is no problem, an MOV may save cost over the transient suppressor diode and will also provide a non-polarized relay.

The use of a reversed-biased rectifier diode in series with a zener diode will provide the best solution when the relay can be polarized. This suppression is often recommended by Siemens Electromechanical Components (SEC) for use in automotive circuits. The impact on release dynamics is minimal and poses no loss of reliability. This is normally a low-cost method and the only design precaution is to select a zener with an appropriate breakdown voltage and impulse power specifications adequate for the relay in its application. In printed circuit board applications with transistors used as relay drivers, the zener diode can be placed "across" the transistor; that is, for a common emitter circuit, cathode connected to collector and anode connected to the emitter (the series rectifier diode is not used in this type of circuit).

A reversed-biased rectifier in series with a resistor may be used successfully with some relays when maximum load switching capacity is not required. Care must be taken to use a resistor large enough in value to quickly dissipate the relay's stored energy but yet stay within the desired peak voltage transient. The required resistor value may be approximated from the following equation:

$$R = V_{\text{peak}} / I_{\text{coil}}$$

where;

R = resistor value in Ohms

V_{peak} = peak transient voltage permitted

I_{coil} = steady-state relay coil current

The actual voltage peak observed will be lower than calculated by this formula due to energy losses in the resistor. When using this type of suppression it is best to consult the relay manufacturer for recommended values.

A resistor may also be used by itself as a transient suppressor when the additional power dissipation and resulting heat generated by the resistor can be tolerated. In most situations, this will provide the least expensive suppression method (assuming the resistor value can be properly sized to minimize its impact on relay performance). This method is normally recommended by SEC when the application requirements permit.

Many engineers use a rectifier diode alone to provide the transient suppression for relay coils. While this is cost effective and fully eliminates the transient voltage, its impact on relay performance can be devastating. Problems of unexplained, random "tack welding" frequently occur in these systems. In some applications, this problem is merely a minor nuisance or inconvenience and the controller or operator will cycle the relay until the proper response is obtained. In many applications; however, the first occurrence may cause a complete system failure or even present a hazardous situation. It is important that these systems be designed with another method of relay suppression.

To illustrate the impact of various coil suppression on the relay response time, consider the following data that was recorded using an automotive ISO type relay with a 55 ohm coil and with 13.5VDC applied to the coil.

Suppression Technique	Drop-out Time (ms)	Theoretical Transient	Recorded Transient
Unsuppressed	1.5		-750
Diode & 24V Zener	1.9	-24.8	-25
680Ω Resistor	2.3	-167	-120
470Ω Resistor	2.8	-115	-74
330Ω Resistor	3.2	-81	-61
220Ω Resistor	3.7	-54	-41
100Ω Resistor	5.5	-24.6	-22
82Ω Resistor	6.1	-20.1	-17
Diode	9.8	-0.8	-0.7

Suggested Methods for Relay Coil Suppression

From the standpoint of physics, the suggested technique for relay coil transient suppression is to use a reversed-biased rectifier diode and series zener diode in parallel with the relay coil. This permits the relay to have optimum release dynamics and normally-open contact life. Such suppression may be incorporated easily into the circuitry for printed circuit board relays; however, when specifying suppression for a socket-mounted relay, this method may be less practical than using a resistor.

When the permissible transient voltage is large enough and power dissipation tolerable, the relay may be suppressed with a resistor. From the standpoint of a Failure Mode and Effects Analysis (FMEA), the resistor will provide less added risk of failure than the two diodes suggested above (provided that its value is high enough to avoid detrimental effects to the relay's release dynamics). It must be noted that the optimum resistor value for one type of relay will not necessarily be the right value for another type.

Now that we have provided suggested suppression techniques based on normally-open contact performance, we must add a qualifying comment concerning the normally-closed contacts. When the primary load is on the normally-closed contacts (and a small load or none on the normally-open), it may be desirable to use a rectifier diode alone as the relay suppression (or perhaps a rectifier diode and a lower value of series resistor). The retarded armature motion that adversely impacts normally-open contact performance will typically improve normally-closed contact performance. The improvement results from less contact bounce during closure of the normally-closed contacts. This results from the lower impact velocity created by the retarded armature motion and has been utilized in the past to improve normally-closed contact performance on certain relays.